

RF MICROWAVE COMPONENTS

Coaxial Terminations



COMPANY Profile

Founded in 1952 in France, Radiall started as a family owned company making coaxial plugs. Today, Radiall is an international and global manufacturer of interconnect components including **RF coaxial connectors and cable assemblies, antennas, fiber optic components, microwave components, and multipin connectors** for the Automotive, Civil Aviation, Defense, Industrial, Medical, Space and Telecommunications.



QSE (Quality Safety Environment) POLICY

Radiall maintains a quality management system conforming to international standards, including for environmental protection. Our customers' recognition for the quality of our products and the sustainability of our company, demonstrates the efficiency of our quality system.



CERTIFICATIONS

Certified ISO 9001 since 1994, Radiall has a pro-active policy in terms of conforming to international standards. Today, all Radiall sites are certified to **ISO 9001:2000** and some

dedicated activities are AS9100 or TS 16949. Our process approach gives us the tool for continuous improvement in all our activities.



A major step in our environment policy was the **ISO 14001** certification in 2001 of the Voreppe plant. Radiall complies with European directives such as **RoHS** for hazardous substance restrictions and **EuP** for environmentally friendly designs for energy-using products.

Some Radiall product lines are on **MIL, ESA/SCC** Qualified Product Lists.

Radiall is consequently proud to be recognized by leading industrial customers for the quality of its service and products.



A WORLDWIDE ENGINEERING & MANUFACTURING CAPABILITY

With expertise centers and manufacturing locations in 3 continents. Radiall offers its customers, through 12 industrial sites, the proximity they need to obtain the best quality of service and delivery performance. Our facilities feature state of the art equipment for the many technologies involved in the design, manufacturing and assembly of interconnect products. Manufacturing plants based in **China, India, Tunisia** and **Mexico** give the opportunity to offer Radiall quality at competitive prices.

Technical information and sales contacts are available on: www.radiall.com

	PAGES
TECHNICAL INFORMATION	4 to 8
SELECTION GUIDE	9 to 11
MINIATURE COAXIAL TERMINATIONS	12 to 20
STANDARD COAXIAL TERMINATIONS	21 to 37
CALIBRATED TERMINATION SET	33
EUROPEAN MILITARY APPROVED COAXIAL TERMINATIONS	38
E.S.A./S.C.C. SPACE QUALIFIED COAXIAL TERMINATIONS	39 - 40
SPECIFIC TERMINATION DESIGN AND CONFIGURATIONS	41
PART NUMBERS INDEX	42

I DEFINITION

A coaxial termination is intended to terminate a coaxial transmission in its characteristic impedance. It is supposed to dissipate the whole R.F. incident power; heat transfer is done by conduction or convection cooling.

II GENERAL SPECIFICATIONS

In general, RADIALL terminations are designed in accordance with MIL and NF standards.

► TECHNOLOGY

Coaxial terminations can be classified technically into 3 main types depending upon the resistive element used.

- High frequency and low power terminations use Tantalum nitride thin film deposits on Alumina substrates.
- High frequency and medium power RADIALL terminations use Tantalum Nitride thin film deposits on Aluminium Nitride substrates.
- High power RADIALL terminations use Ruthenium Oxide thick film circuits printed on alumina substrates stucked to a sole of aluminium nitride as a cooling sink.

RADIALL has decided to remove Beryllium material from its whole range of medium and high power terminations. Indeed, Beryllium oxide dust is highly toxic when scribing or machining or laser trimming. RADIALL has replaced this material by aluminium nitride which has excellent heat conductive properties and is absolutely safe for the environment.

► MECHANICAL CHARACTERISTICS, MATERIALS AND FINISHES

All materials and finishes are in accordance with applicable MIL and NF specifications.

All connectors used in our terminations are in accordance with applicable MIL DIN NF and CEI specifications.

All dimensions in this catalogue are given in inches and (millimeters). The non-specified dimensions are given within ± 0.5 mm.

► MANUFACTURING AND QUALITY ASSURANCE

Thin film and thick film circuits of RADIALL terminations are produced in-house, in class 10000 clean rooms, using advanced processing technologies. Our microelectronic laboratory uses a tightly controlled and highly repeatable process, necessary to achieve consistent microwave performances.

RADIALL maintains a state-of-the-art computer aided designed system, a well equipped precision machine factory, a modern component assembly area and an extensive collection of RF test equipments.

Specific testing is available upon request.

III LIST OF APPLICABLE DOCUMENTS :

List of related standards covering the general mechanical and climatic tests applicable to the devices described in this catalog.

- AIR 7304
- CEI 169.13
- DIN 47295
- GAM EG 13
- NFC 207xx
- NFC 93561
- NFC 93562
- NFC 93563
- NFC 93564
- NFC 93566
- NFC 96315
- MIL C 39012
- MIL D 39030
- MIL E 5400
- MIL STD 202

IV ENVIRONMENTAL CHARACTERISTICS :

	Operating temperature range	Storage temperature range
All the models	- 55°C, + 125°C	- 55°C, + 125°C

V MATERIALS AND FINISHES :

Body	Passivated Stainless Steel or Brass Nickel plated
Contact	Beryllium Copper Gold plated (UBe2)
Heatsink	Aluminium black anodized
Insulator	P T F E or ULTEM 1000
Resistor circuits	Tantalium Nitride Thin film on ceramic substrates Ruthenium Oxide Thick film on ceramic substrates Tantalium Nitride Thin film on Aluminium nitride substrates Non inductive resistor

VI TEMPERATURE POWER DERATING CURVE :

a) FOR 6 AND 12 WATTS MODELS

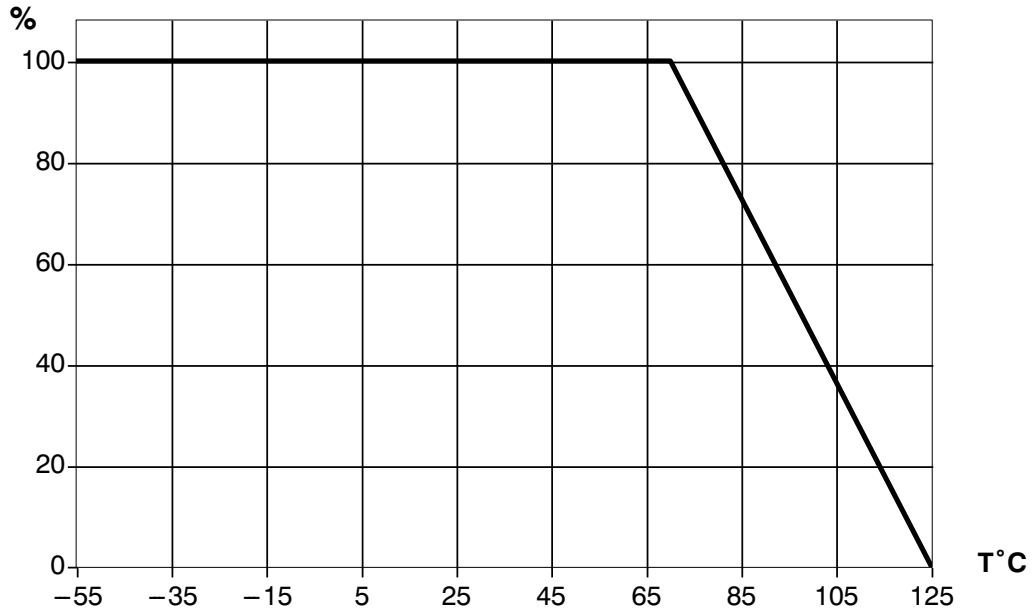

b) FOR ALL OTHER MODELS

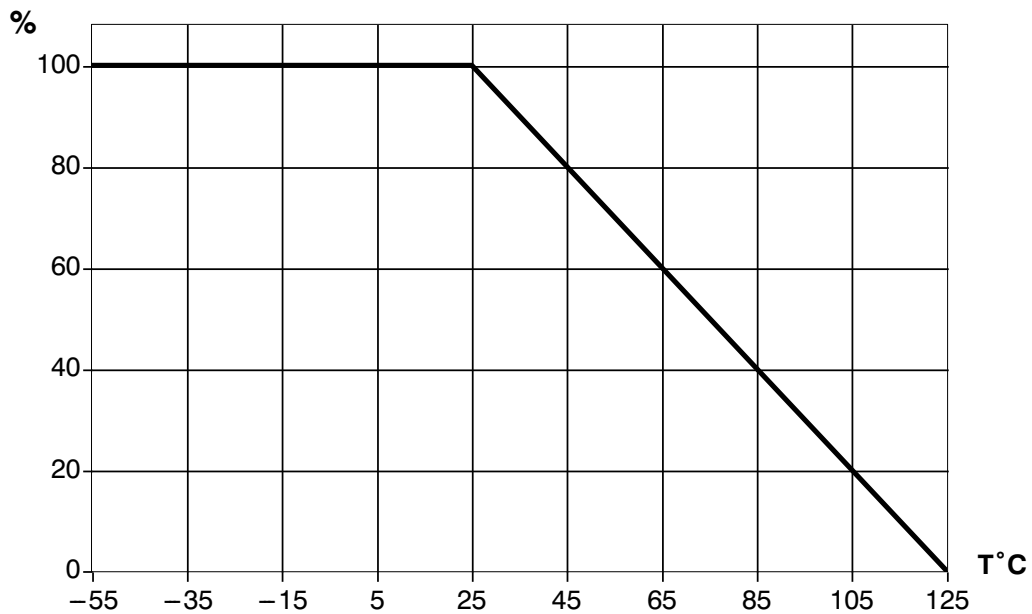

VII DEFINITIONS OF TERMINATION RELATED PARAMETERS

► CONNECTORS

Microwave connectors have a characteristic impedance from 50 to 75 ohms. Adaptation interfaces, materials and platings are in accordance with the applicable specifications quoted in this catalog.

► FREQUENCY RANGE

The frequency range indicated for each device is the range over which RADIALL specifies the device performance.

► AVERAGE POWER HANDLING

It is the maximum CW input power applied for a long time at room temperature, or at the maximum temperature of 75°C, that the termination can handle without permanently changing the specifications of the component. Any overpowering beyond this limit can significantly alter the input power handling of the termination.

► PEAK POWER HANDLING

It is the maximum peak power which, when applied at maximum room temperature under a pulse of one microsecond every millisecond, will not permanently change the specifications of the termination. Any overpowering beyond this limit will alter the input power handling of the termination.

► V.S.W.R.

The **V**oltage **S**tanding **W**ave **R**atio is a measure of the return loss or level of the reflected signal of a device connected on a transmission line.

V.S.W.R. is linked to the coefficient of reflection (ρ) by the equation :

$$\text{V.S.W.R.} = \frac{1 + |\rho|}{1 - |\rho|}$$

$$\text{with } \rho = \frac{Z - Z_0}{Z + Z_0} \quad \begin{array}{l} (Z \text{ is the component impedance}) \\ (Z_0 \text{ is the characteristic impedance of the line}) \end{array}$$

(ρ) represents the coefficient of reflection vector standard

Variation within 0 and 1, V.S.W.R. equal to 1 represents the perfect adaptation. This value can be expressed in dB's and is known as return loss, when expressed as $20\log_{10} |\rho|$

► IMPEDANCE

In DC current, the impedance corresponds to the resistor value of the termination. As the frequency increases, the impedance characterizes the component adaptation which is measured by the V.S.W.R. The most common value is $50\ \Omega$ (or $75\ \Omega$). Nevertheless, some applications require to be voluntarily unadapted. That is why some RADIALL termination part numbers have a deliberately shifted impedance in order to obtain a V.S.W.R different from 1.

► RESISTIVE PAD

We call "resistive PAD", components with a specified resistance but which impedance is not guaranteed at high frequencies.

► FEEDTHROUGH TERMINATIONS

These terminations are used to match $Z_c = 50\ \Omega$ or $75\ \Omega$ lines to high impedance inputs of electronic instruments (for example an oscilloscope has typically a $1\text{M}\Omega$ input impedance).

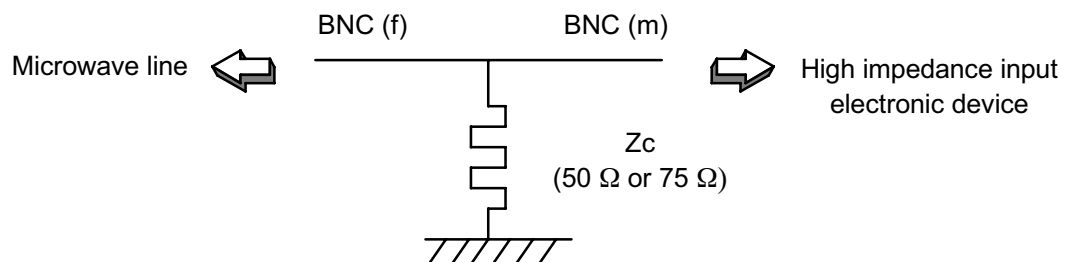

► CONDUCTION AND CONVECTION COOLING

Heat dissipation for medium and high power terminations can be done by convection or conduction cooling.

- Convection cooling :

The termination is equipped with a heat sink with cooling fins. A heat sink with cooling fins increases the effective heat exchange toward the environment. The heat sink is characterized by its thermal resistance or by the increase of surface temperature per watt (in $^{\circ}\text{C}$ per W). The shorter this value is, the greater the power will be. Cooling shapes and sizes have an important effect on this parameter.

- Conduction cooling :

The component has to be mounted to a heat sink, plate or chassis of the equipment to ensure a good heat transfer. The dimensions of the plate or chassis are calculated according to the characteristics of the components.

0.5 WATT

SMP	p 12
SMA 2.9	p 13
SMB	p 18
SMC	p 19
SSMA	p 20

1 WATT

DIN 1.0 / 2.3	p 12
QMA	p 12
SMA	p 13
SMB	p 18
BMA	p 20
BNC	p 21-22
TNC	p 23
QN	p 28
N	p 28

2 WATTS

SMA	p 13
TNC	p 23
N	p 28
7/16	p 34

3 WATTS

QMA	p 12
-----	------

6 WATTS - 12 WATTS

SMA	p 14
BNC	p 22
TNC	p 24
N	p 29
7/16	p 34

20 WATTS

SMA	p 15
TNC	p 24
N	p 30

25 WATTS

7/16	p 34
------	------

30 WATTS

SMA	p 15
TNC	p 25
N	p 30

50 WATTS

SMA	p 16
TNC	p 25-26
N	p 31
7/16	p 35

100 WATTS

SMA	p 17
TNC	p 26
N	p 32
7/16	p 36

120 WATTS

SMA	p 17
TNC	p 27
N	p 32

CALIBRATED SET	p 33
FEEDTHROUGH	p 37
SPACE	p 39-40

MINIATURE COAXIAL TERMINATIONS

Connector	Average Power (W)	Frequency range (GHz)	Impedance (Ω)	Page
SMP	0.5	DC - 40	50	12
DIN 1.0/2.3	1	DC - 2.5		12
QMA	1	DC - 4	50	12
	3	DC - 2.5		
SMA 2.9	0.5	DC - 40	50	13
SMA	1	DC - 4 DC - 18		
	2	DC - 18 DC - 26.5		
	6 / 12 / 20	DC - 12.4 DC - 18		
	30 / 50 / 100 / 120	DC - 4		14 - 15
SMB	0.5	DC - 8	50	18
	1	DC - 4		
SMC	0.5	DC - 8	50	19
BMA	1	DC - 18	50	20
SSMA	0.5	DC - 18	50	20

STANDARD COAXIAL TERMINATIONS

Connector	Average Power (W)	Frequency (GHz)	Impedance (Ω)	Page
BNC	1	Resistive PAD	50 - 75 - 93	22
		DC-1	75	21-22
		DC-4 DC-8 DC-11	50	21
	6 / 12	DC - 2 DC - 8	50	22
TNC	1	DC - 4 DC - 12.4	50	23
	2	DC - 18		24
	6/12	DC - 2 DC - 12.4 DC - 18		
		20		
	30/50/100	DC - 4		
	120			27
QN	1	DC - 4	50	28
N	1	DC - 1.5	75	28
		DC - 4 DC - 12.4	50	
	2	DC - 18		
	6/12	DC - 2 DC - 12.4 DC - 18		29
		20		DC - 12.4 DC - 18
	30	DC - 4		31
	50			32
	100/120			33
	1 (**)	50		34
7/16	2/12/25	DC - 4		50
	50/100	DC - 2		
BNC(*)	2	DC - 1	50 - 75	37

(*) Feedthrough termination

(**) Calibrated termination set

0.5 WATT SMP

Part Number	Power		Frequency range (GHz)	V.S.W.R. (MAX)			Impedance (Ω)	Type	Fig.
	avg. (W)	peak (W)		DC-18	18-26.5	26.5-40			
R404 260 000		100	DC - 40	1.20	1.35	1.70	50 \pm 5%	M	1
R404 262 000		100	DC - 40	1.20	1.35	1.70	50 \pm 5%	F	2

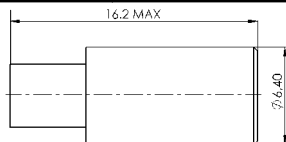

Fig. 1

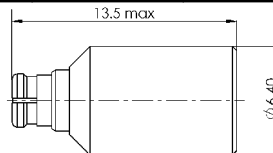
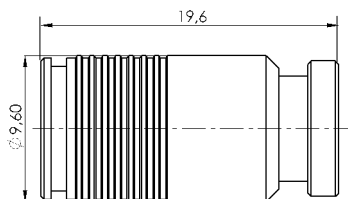

Fig. 2

1 WATT DIN 1.0/2.3

Part Number	Power		Frequency range (GHz)	V.S.W.R. (MAX)	Impedance (Ω)	Type
	avg. (W)	peak (W)		DC-2.5		
R404 144 000		100	DC-2.5	1.15	50 \pm 5%	M



1 - 3 WATTS QMA

Part Number	Power		Frequency range (GHz)	V.S.W.R. (MAX)			Impedance (Ω)	Type	Obs.
	avg. (W)	peak (W)		DC-1	1-2.5	1-4			
R404 114 000	1	100	DC-4	1.08	-	1.20	50 \pm 5%	M	-
R404 114 120	1	100	DC-4	1.08	-	1.20	50 \pm 5%	M	1
R404 114 121	1	100	DC-4	1.08	-	1.20	50 \pm 5%	M	2
R404 114 250	3	500	DC-2.5	-	1.10	-	50 \pm 5%	M	-

OBS :1) With 2.75" (70 mm) Bead Chain

2) With 2.75" (70 mm) Cord

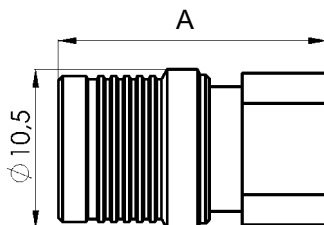

Part Number	A
R 404 114 000	17,7
R 404 114 120	17,7
R 404 114 121	17,7
R 404 114 250	25

Technical data sheet are available under the www.radiall.com Web site Select "Find a part number", enter the part number then "Search"

0.5 WATTS SMA 2.9

Part Number	Power		Frequency range (GHz)	V.S.W.R. (MAX)						Imp. (Ω)	Type	Obs
	avg. (W)	peak (W)		DC-1	1-4	4-8	8-12.4	12.4-18	18-26.5			
R404 280 000	0.5	100	DC-40	1.35						50±5%	M	1
R404 285 000	0.5	100	DC-40	1.35						50±5%	F	1

1 - 2 WATTS SMA

Part Number	Power		Frequency range (GHz)	V.S.W.R. (MAX)						Imp. (Ω)	Type	Obs
	avg. (W)	peak (W)		DC-1	1-4	4-8	8-12.4	12.4-18	18-26.5			
R404 101 000	1	100	DC- 4	1.08	1.20					50±5%	M	
R404 101 120	1	100	DC- 4	1.08	1.20					50±5%	M	3
R404 102 000	1	100	DC- 4	1.08	1.20					50±5%	F	
R404 102 120	1	100	DC- 4	1.08	1.20					50±5%	F	3
R404 212 000	1	100	DC-18	1.08		1.12	1.16	1.20		50±5%	M	2
R404 212 120	1	100	DC-18	1.08		1.12	1.16	1.20		50±5%	M	2-4
R404 212 122	1	100	DC-18	1.08		1.12	1.16	1.20		50±5%	M	2-5
R404 210 000	2	100	DC-18	1.10		1.18	1.25			50±5%	M	
R404 210 120	2	100	DC-18	1.10		1.18	1.25			50±5%	M	4
R404 210 161	2	100	DC-18	1.10		1.18	1.25			50±2%	M	
R404 215 000	2	100	DC-18	1.10		1.18	1.25	1.40		50±5%	F	
R404 213 000	2	100	DC-26.5	1.05		1.10		1.20	1.30	50±5%	M	
R404 219 000	2	100	DC-26.5	1.05		1.15		1.20	1.30	50±5%	F	

OBS :1) SMA 2.9 connector 100% Compatible with K® connector

2) Type SMA connector, 100 Connect-Disconnect cycles maximum. Connector mate non destructively with SMA per MIL C 39012

3) With 2.75" (70 mm) Bead Chain

4) With 2.75" (70 mm) Cord

5) With 3.54" (90 mm) Bead Chain

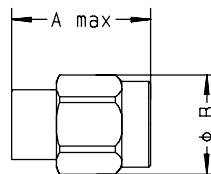

Part Number	A inch (mm)	B inch (mm)	Weight (g)
R404 101 000	.36" (9.30)	.35" (9.0)	3
R404 101 120	.49" (12.5)		8
R404 102 000	.39" (10.0)		3
R404 102 120	.51" (13.0)		8
R404 210 000			3
R404 210 120	.56" (14.3)		8
R404 210 161	.51" (13.0)		3

Part Number	A inch (mm)	B inch (mm)	Weight (g)
R404 212 000	.36" (9.30)	.35" (9.0)	3
R404 212 120	.44" (11.2)		8
R404 212 122			5
R404 213 000	.65" (16.5)		5
R404 215 000	.45" (11.5)	.31" (8.0)	2
R404 219 000	.59" (15.0)	.30" (7.6)	4
R404 280 000	.72" (18.4)	.35" (9.0)	5
R404 285 000	.76" (19.3)	.30" (7.6)	4

K® : Trade Mark of WILTRON

Technical data sheet are available under the www.radiall.com Web site Select "Find a part number", enter the part number then "Search"

6 - 12 WATTS MEDIUM POWER

Part Number	Power		Frequency range (GHz)	V.S.W.R. (MAX)				Imp. (Ω)	Type
	avg. (W)	peak (W)		DC-4	4-8	8-12.4	12.4-18		
R404 518 000	6	4000	DC-12.4	1.10	1.20	1.30		50 \pm 5%	M
R404 518 500	6	4000	DC-12.4	1.10	1.20	1.30		50 \pm 5%	F
R404 523 000	6	300	DC-18	1.15	1.20	1.25	1.30	50 \pm 5%	M
R404 523 500	6	300	DC-18	1.15	1.20	1.25	1.30	50 \pm 5%	F
R404 568 000	12	4000	DC-12.4	1.10	1.20	1.30		50 \pm 5%	M
R404 568 500	12	4000	DC-12.4	1.10	1.20	1.30		50 \pm 5%	F
R404 573 000	12	300	DC-18	1.15	1.20	1.25	1.30	50 \pm 5%	M
R404 573 500	12	300	DC-18	1.15	1.20	1.25	1.30	50 \pm 5%	F

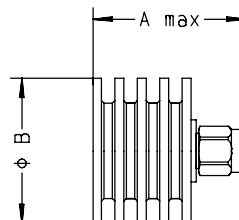

Part Number	A inch (mm)	B inch (mm)	Weight (g)
R404 518 000	1.22" (31)	1.02 (26)	22
R404 518 500	1.08" (27.5)		
R404 523 000	1.85" (47)		45
R404 523 500	1.80" (45.8)		

Part Number	A inch (mm)	B inch (mm)	Weight (g)
R404 568 000	1.73" (44)	1.38" (35)	62
R404 568 500	1.59" (40.5)		
R404 573 000	2.05" (52.2)		75
R404 573 500	2.00" (51)		

Technical data sheet are available under the www.radiall.com Web site Select "Find a part number", enter the part number then "Search"

20 WATTS MEDIUM POWER

Part Number	Power peak (W)	Frequency range (GHz)	V.S.W.R. (MAX)				Imp. (Ω)	Type	Weight (g)
			DC-4	4-8	8-12.4	12.4-18			
R404 584 000	300	DC-12.4	1.15	1.20	1.25		50 \pm 5%	M	80
R404 584 500	300	DC-12.4	1.15	1.20	1.25		50 \pm 5%	F	80
R404 589 000	300	DC-18		1.20	1.25	1.35	50 \pm 5%	M	80
R404 589 500	300	DC-18		1.20	1.25	1.35	50 \pm 5%	F	80

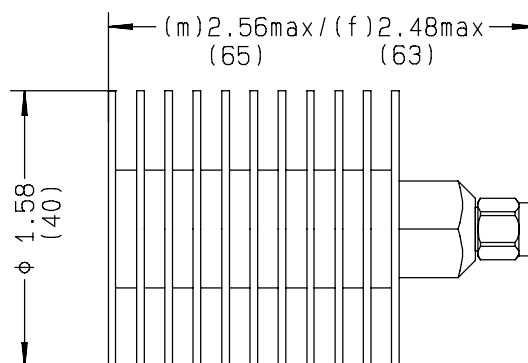

30 WATTS MEDIUM POWER

Part Number	Power peak (W)	Frequency range (GHz)	V.S.W.R. (MAX)		Imp. (Ω)	Type	Weight (g)
			DC-2	2-4			
R404 834 000	5000	DC-4	1.10	1.20	50 \pm 5%	M	125
R404 835 000	5000	DC-4	1.10	1.20	50 \pm 5%	F	125

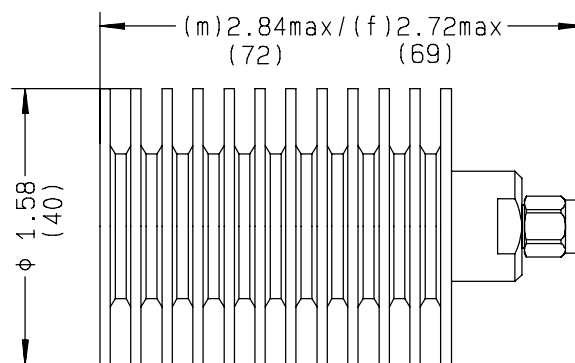

Coaxial Terminations

MINIATURE COAXIAL TERMINATIONS SMA

50 WATTS MEDIUM POWER without cooling fins

Part Number	Power peak (W)	Frequency range (GHz)	V.S.W.R. (MAX)		Impedance (Ω)	Type	Weight (g)
			DC-2	2-4			
R404 874 000	5000	DC-4	1.10	1.20	50 \pm 5%	M	140
R404 875 000	5000	DC-4	1.10	1.20	50 \pm 5%	F	140

NOTA : This termination can be used with conduction cooling (50 Watts) or convection cooling (25 Watts).
For conduction cooling a 78 sq. in. plate x 1/8" (500 cm² x 3 mm) min. is required.

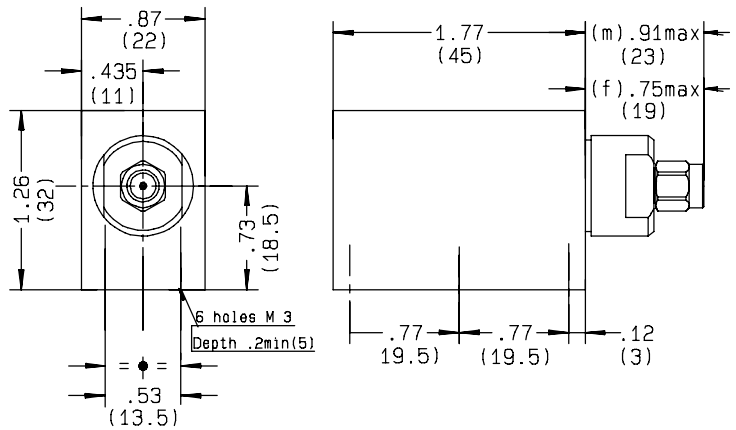

50 WATTS MEDIUM POWER with cooling fins

Part Number	Power peak (W)	Frequency range (GHz)	V.S.W.R. (MAX)		Impedance (Ω)	Type	Weight (g)
			DC-2	2-4			
R404 844 000	5000	DC-4	1.10	1.20	50 \pm 5%	M	320
R404 845 000	5000	DC-4	1.10	1.20	50 \pm 5%	F	320

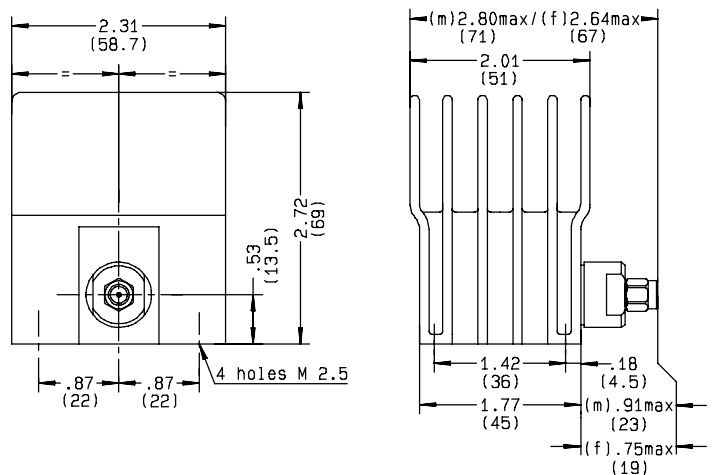

Technical data sheet are available under the www.radiall.com Web site Select "Find a part number", enter the part number then "Search"

Coaxial Terminations

MINIATURE COAXIAL TERMINATIONS SMA

100 WATTS HIGH POWER

Part Number	Power peak (W)	Frequency range (GHz)	V.S.W.R. (MAX)			Impedance (Ω)	Type	Weight (g)
			DC-1	1-2	2-4			
R404 854 000	5000	DC-4	1.10	1.20	1.30	50 \pm 5%	M	1000
R404 855 000	5000	DC-4	1.10	1.20	1.30	50 \pm 5%	F	1000

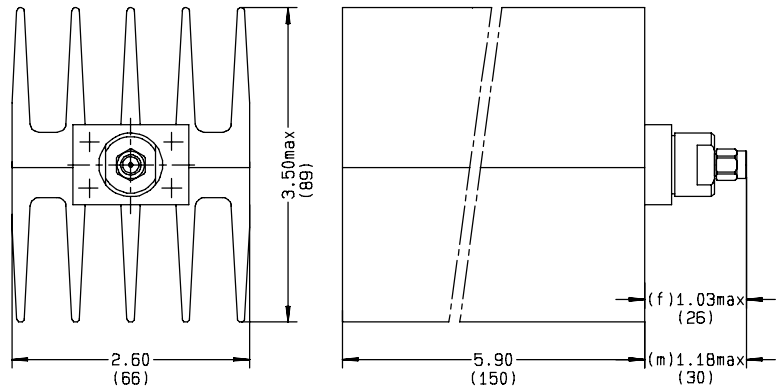
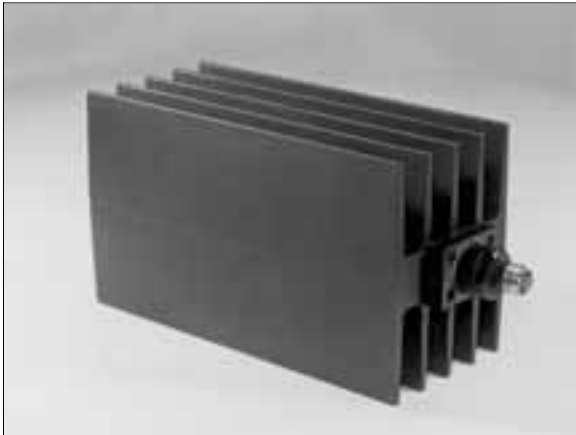

120 WATTS HIGH POWER

Part Number	Power peak (W)	Frequency range (GHz)	V.S.W.R. (MAX)			Impedance (Ω)	Type	Weight (g)
			DC-1	1-2	2-4			
R404 884 000	5000	DC-4	1.10	1.20	1.30	50 \pm 5%	M	800
R404 885 000	5000	DC-4	1.10	1.20	1.30	50 \pm 5%	F	800

NOTA : This termination can be used with conduction cooling (120 Watts) or convection cooling (80 Watts).
For conduction cooling a 156 sq. in. plate x $\frac{1}{8}$ " (1000 cm² x 3 mm) min. is required.

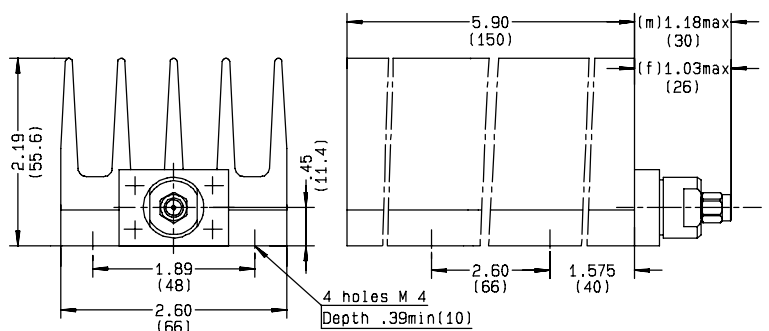

Technical data sheet are available under the www.radiall.com Web site Select "Find a part number", enter the part number then "Search"

0.5 - 1 WATT

Part Number	Power		Frequency range (GHz)	V.S.W.R. (MAX)			Impedance (Ω)	Type	Obs.
	avg. (W)	peak (W)		DC2.5	2.5-4	4-8			
R404 104 000	1	100	DC-4	1.10	1.20		50 \pm 5%	M	
R404 104 120	1	100	DC-4	1.10	1.20		50 \pm 5%	M	2
R404 105 000	1	100	DC-4	1.10	1.20		50 \pm 5%	F	
R404 105 120	1	100	DC-4	1.10	1.20		50 \pm 5%	F	2
R404 155 000	0.5	100	DC-8	1.10	1.20	1.25	50 \pm 5%	F	1
R404 165 000	0.5	100	DC-8	1.10	1.20	1.25	50 \pm 5%	F	

OBS :1) With .275" (70mm) cord

OBS :2) With .275" (70mm) bead chain

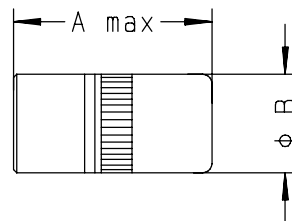

Part Number	A inch (mm)	B inch (mm)	Weight (g)
R404 104 000	.45" (11.4)	.27" (7)	2
R404 104 120	.57" (14.4)		7
R404 105 000	.45" (11.3)	.28" (7.2)	2
R404 105 120	.57" (14.3)		7
R404 155 000	.59" (15)	.25" (6.4)	8
R404 165 000	.53" (13.5)		3

Technical data sheet are available under the www.radiall.com Web site Select "Find a part number", enter the part number then "Search"

Coaxial Terminations

MINIATURE COAXIAL TERMINATIONS SMC

0.5 WATT

Part Number	Power peak (W)	Frequency range (GHz)	V.S.W.R. (MAX)			Impedance (Ω)	Type	Obs.
			DC2.5	2.5-4	4-8			
R404 150 000	100	DC-8	1.10	1.20	1.25	$50 \pm 5\%$	F	1
R404 160 000	100	DC-8	1.10	1.20	1.25	$50 \pm 5\%$	F	

OBS :1) With .275" (70mm) cord

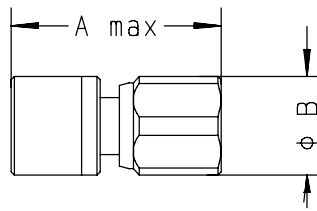

Part Number	A inch (mm)	B inch (mm)	Weight (g)
R404 150 000	.63" (16)	.25" (6.4)	8
R404 160 000	.57" (14.5)		3

Technical data sheet are available under the www.radiall.com Web site Select "Find a part number", enter the part number then "Search"

Coaxial Terminations

MINIATURE COAXIAL TERMINATIONS SSMA, BMA

0.5 WATT SSMA

Part Number	Power peak (W)	Frequency range (GHz)	V.S.W.R. (MAX)			Impedance (Ω)	Weight (g)	Type
			DC-4	4-12.4	12.4-18			
R404 380 000	100	DC-18	1.10	1.15	1.35	50 \pm 5%	4	M

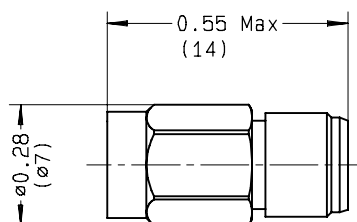

1 WATT BMA*

Part Number	Power peak (W)	Frequency range (GHz)	V.S.W.R. (MAX)			Impedance (Ω)	Type
			DC-4	4-12.4	12.4-18		
R404 270 000	100	DC-18	1.10	1.10	1.20	50 \pm 5%	M
R404 275 000	100	DC-18	1.10	1.15	1.30	50 \pm 5%	F

* Compatible OSP®

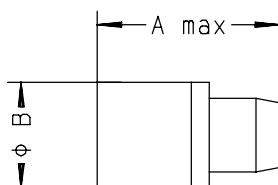

Part Number	A inch (mm)	B inch (mm)	Weight (g)
R404 270 000	.53" (13.5)	.30" (7.7)	3
R404 275 000	.57" (14.5)		3.5

OSP® Trade mark of OSM

Technical data sheet are available under the www.radiall.com Web site Select "Find a part number", enter the part number then "Search"

1 WATT

Part Number	Power peak (W)	Frequency range (GHz)	V.S.W.R. (MAX)					Impedance (Ω)	Type	Obs.
			DC-0.5	0.5-1	1-4	4-8	8-11			
R404 010 000	500	DC-1							M	1
R404 010 120	500	DC-1							M	1-3
R404 012 000	500	DC-1	1.08	1.15				75 \pm 2%	M	2
R404 012 120	500	DC-1	1.08	1.15				75 \pm 2%	M	2-3
R404 014 000	500	DC-1	1.08	1.15				75 \pm 2%	F	2
R404 014 120	500	DC-1	1.08	1.15				75 \pm 2%	F	2-3
R404 111 000	500	DC-4	1.08		1.20			50 \pm 2%	M	
R404 111 120	500	DC-4	1.08		1.20			50 \pm 2%	M	3
R404 111 121	500	DC-4	1.08		1.20			50 \pm 2%	M	4
R404 112 000	500	DC-4	1.08		1.20			50 \pm 2%	F	
R404 112 120	500	DC-4	1.08		1.20			50 \pm 2%	F	3
R404 110 000	500	DC-8	1.10		1.20	1.25		50 \pm 5%	M	5
R404 110 120	500	DC-8	1.10		1.20	1.25		50 \pm 5%	M	3-5
R404 220 000	500	DC-11	1.10			1.25		50 \pm 5%	M	
R404 220 120	500	DC-11	1.10			1.25		50 \pm 5%	M	3

OBS : 1) Specific values of DC resistance: To be specified on order
 2) 75 Ohms Connector
 3) With 2.75" (70 mm) Bead Chain

4) With 2.75" (70 mm) Cord
 5) VSWR < 1.10 up to 2 GHz

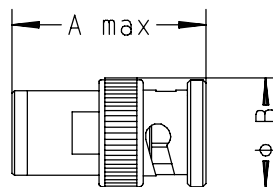

Part Number	A inch (mm)	B inch (mm)	Weight (g)
R404 012 000	1.22" (31)	.57" (14.5)	15
R404 012 120			20
R404 014 000	1.14" (29)	.43" (11.0)	15
R404 014 120	20		
R404 110 000	1.30" (33)	.57" (14.5)	15
R404 110 120			20

Part Number	A inch (mm)	B inch (mm)	Weight (g)
R404 111 000	1.06" (27)	.57" (14.5)	15
R404 111 120	1.22" (31)		20
R404 111 121			15
R404 112 000	1.14" (29)	.43" (11.0)	15
R404 112 120	20		
R404 220 000	1.30" (33)	.57" (14.5)	15
R404 220 120			20

Technical data sheet are available under the www.radiall.com Web site Select "Find a part number", enter the part number then "Search"

1 WATT

Part Number	Power	Frequency range (GHz)	Technical design	Impedance (Ω)	Type	Obs.	Weight (g)
	peak (W)						
R404 412 000	500	DC-1	resistive PAD	75 \pm 0.1%	M	1	15
R404 441 000	500	DC-1	resistive PAD	50 \pm 1%	M		15
R404 441 120	500	DC-1	resistive PAD	50 \pm 1%	M	2	20
R404 441 121	500	DC-1	resistive PAD	50 \pm 1%	M	3	20
R404 442 000	500	DC-1	resistive PAD	75 \pm 1%	M	1	15
R404 442 120	500	DC-1	resistive PAD	75 \pm 1%	M	1-2	20
R404 443 000	500	DC-1	resistive PAD	93 \pm 1%	M	1	15
R404 443 120	500	DC-1	resistive PAD	93 \pm 1%	M	1-2	20

OBS :1) 75 Ohms Connector

2) With 2.75" (70 mm) Bead Chain

3) With 2.75" (70 mm) Cord

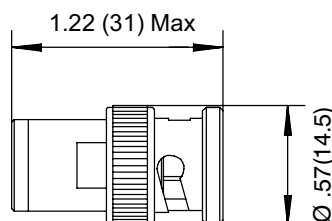

6 - 12 WATTS MEDIUM POWER

Part Number	Power		Frequency range (GHz)	V.S.W.R. (MAX)			Impedance (Ω)	Type
	avg. (W)	peak (W)		DC-2	2-4	4-8		
R404 505 000	6	4000	DC-2	1.10			50 \pm 5%	M
R404 510 000	6	4000	DC-8	1.10	1.15	1.25	50 \pm 5%	M
R404 555 000	12	4000	DC-2	1.10			50 \pm 5%	M
R404 560 000	12	4000	DC-8	1.10	1.15	1.25	50 \pm 5%	M

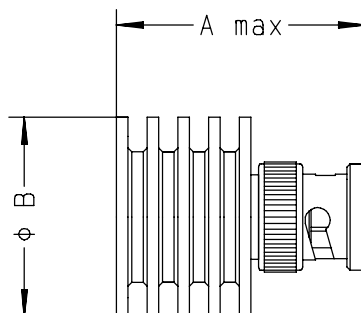

Part Number	A inch (mm)	B inch (mm)	Weight (g)
R404 505 000	1.34" (34.0)	1.02" (26)	26
R404 510 000			

Part Number	A inch (mm)	B inch (mm)	Weight (g)
R404 555 000	1.85" (47.0)	1.38" (35)	70
R404 560 000			

Technical data sheet are available under the www.radiall.com Web site Select "Find a part number", enter the part number then "Search"

1 - 2 WATTS

Part Number	Power		Frequency range (GHz)	V.S.W.R. (MAX)					Impedance (Ω)	Type	Obs
	avg (W)	peak (W)		DC-1	1-4	4-8	8-12.4	12.4-18			
R404 121 000	1	500	DC-4	1.08	1.20				50 \pm 2%	M	
R404 121 120	1	500	DC-4	1.08	1.20				50 \pm 2%	M	1
R404 122 000	1	500	DC-4	1.08	1.20				50 \pm 2%	F	
R404 122 120	1	500	DC-4	1.08	1.20				50 \pm 2%	F	1
R404 225 000	1	500	DC-12.4	1.10		1.15	1.25		50 \pm 5%	M	
R404 225 120	1	500	DC-12.4	1.10		1.15	1.25		50 \pm 5%	M	1
R404 225 121	1	500	DC-12.4	1.10		1.15	1.25		50 \pm 5%	M	2
R404 370 000	2	100	DC-18	1.08		1.10	1.15	1.20	50 \pm 5%	M	
R404 370 120	2	100	DC-18	1.08		1.10	1.15	1.20	50 \pm 5%	M	1
R404 375 000	2	100	DC-18	1.20					50 \pm 5%	F	

OBS :1) With 2.75" (70 mm) Bead Chain

2) With 2.75" (70 mm) Cord

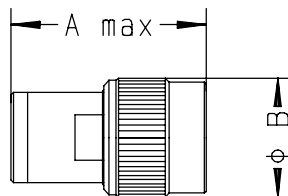

Part Number	A inch (mm)	B inch (mm)	Weight (g)
R404 121 000	1.06" (27)	.57" (14.5)	16
R404 121 120	1.18" (30)		20
R404 122 000	1.14" (29)	.43" (11)	15
R404 122 120	1.30" (33)		20
R404 225 000	1.26" (32)		15

Part Number	A inch (mm)	B inch (mm)	Weight (g)
R404 225 120	1.26" (32)	.57" (14.5)	20
R404 225 121			
R404 370 000	.98" (25)	.63" (16)	23
R404 370 120	1.10" (28)		25
R404 375 000	.90" (23)		.51" (13)

Technical data sheet are available under the www.radiall.com Web site Select "Find a part number", enter the part number then "Search"

6 - 12 WATTS MEDIUM POWER

Part Number	Power		Frequency range (GHz)	V.S.W.R. (MAX)				Imp. (Ω)	Type
	avg. (W)	peak (W)		DC-4	4-8	8-12.4	12.4-18		
R404 506 000	6	4000	DC-2	1.10				50 \pm 5%	M
R404 516 000	6	4000	DC-12.4	1.10	1.20	1.30		50 \pm 5%	M
R404 521 000	6	300	DC-18	1.15	1.20	1.25	1.30	50 \pm 5%	M
R404 521 500	6	300	DC-18	1.15	1.20	1.25	1.30	50 \pm 5%	F
R404 556 000	12	4000	DC-2	1.10				50 \pm 5%	M
R404 566 000	12	4000	DC-12.4	1.10	1.20	1.30		50 \pm 5%	M
R404 571 000	12	300	DC-18	1.15	1.20	1.25	1.30	50 \pm 5%	M
R404 571 500	12	300	DC-18	1.15	1.20	1.25	1.30	50 \pm 5%	F

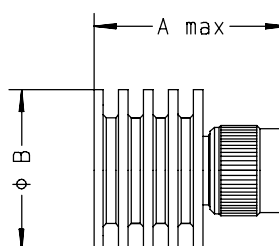

Part Number	A inch (mm)	B inch (mm)	Weight (g)
R404 506 000	1.30" (33)	1.02" (26)	27
R404 516 000			
R404 521 000	1.85" (47)		45
R404 521 500	1.81" (46)		

Part Number	A inch (mm)	B inch (mm)	Weight (g)
R404 556 000	1.81" (46)	1.38" (35)	70
R404 566 000			
R404 571 000	2.04" (52)		75
R404 571 500	2.01" (51)		

20 WATTS MEDIUM POWER

Part Number	Power		Frequency range (GHz)	V.S.W.R. (MAX)				Impedance (Ω)	Type	Weight (g)
	avg. (W)	peak (W)		DC-4	4-8	8-12.4	12.4-18			
R404 585 000	20	300	DC-12.4	1.15	1.20	1.25		50 \pm 5%	M	85
R404 585 500	20	300	DC-12.4	1.15	1.20	1.25		50 \pm 5%	F	85
R404 586 000	20	300	DC-18	1.20		1.25	1.35	50 \pm 5%	M	85
R404 586 500	20	300	DC-18	1.20		1.25	1.35	50 \pm 5%	F	85

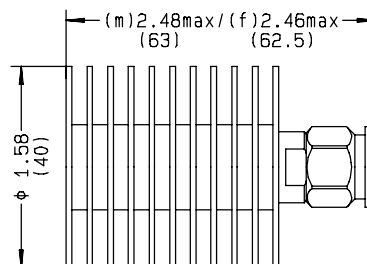

Technical data sheet are available under the www.radiall.com Web site Select "Find a part number", enter the part number then "Search"

Coaxial Terminations

STANDARD COAXIAL TERMINATIONS TNC

30 WATTS MEDIUM POWER

Part Number	Power peak (W)	Frequency range (GHz)	V.S.W.R. (MAX)		Impedance (Ω)	Type	Weight (g)
			DC-2	2-4			
R404 832 000	5000	DC-4	1.10	1.20	50 \pm 5%	M	125
R404 833 000	5000	DC-4	1.10	1.20	50 \pm 5%	F	125

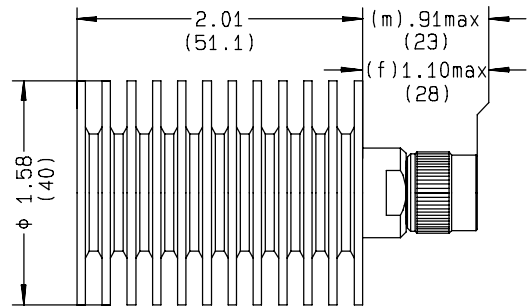

50 WATTS MEDIUM POWER without cooling fins

Part Number	Power peak (W)	Frequency range (GHz)	V.S.W.R. (MAX)		Impedance (Ω)	Type	Weight (g)
			DC-2	2-4			
R404 872 000	5000	DC-4	1.10	1.20	50 \pm 5%	M	140
R404 873 000	5000	DC-4	1.10	1.20	50 \pm 5%	F	140

NOTA : This termination can be used with conduction cooling (50 Watts) or convection cooling (25 Watts).
For conduction cooling a 78 sq. in. plate x 1/8" (500 cm² x 3 mm) min. is required.

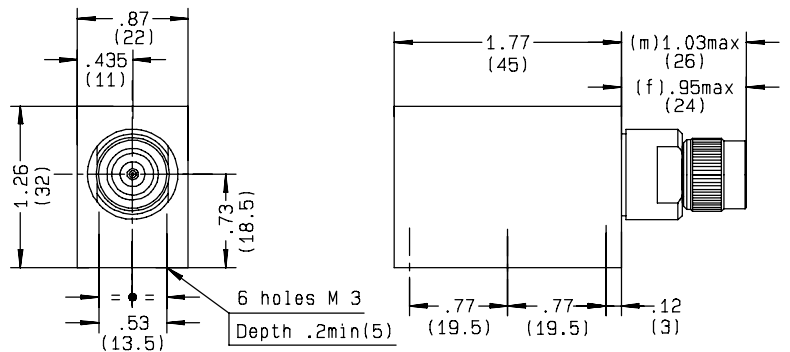

Technical data sheet are available under the www.radiall.com Web site Select "Find a part number", enter the part number then "Search"

Coaxial Terminations

STANDARD COAXIAL TERMINATIONS TNC

50 WATTS MEDIUM POWER with cooling fins

Part Number	Power peak (W)	Frequency range (GHz)	V.S.W.R. (MAX)		Impedance (Ω)	Type	Weight (g)
			DC-2	2-4			
R404 842 000	5000	DC-4	1.10	1.20	50 \pm 5%	M	320
R404 843 000	5000	DC-4	1.10	1.20	50 \pm 5%	F	320

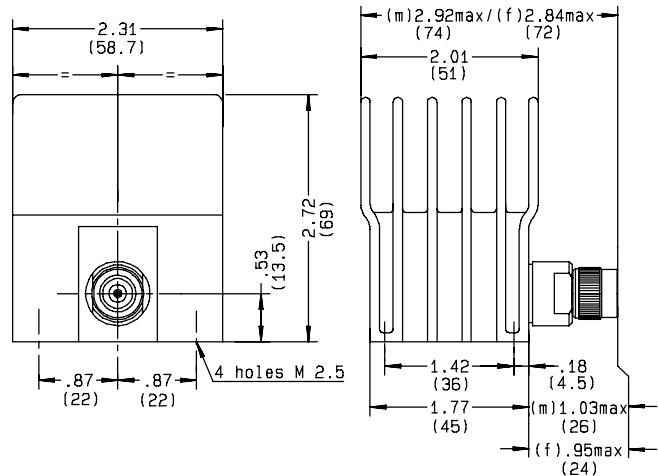

100 WATTS HIGH POWER

Part Number	Power peak (W)	Frequency range (GHz)	V.S.W.R. (MAX)			Impedance (Ω)	Type	Weight (g)
			DC-1	1-2	2-4			
R404 852 000	5000	DC-4	1.10	1.20	1.30	50 \pm 5%	M	1000
R404 853 000	5000	DC-4	1.10	1.20	1.30	50 \pm 5%	F	1000

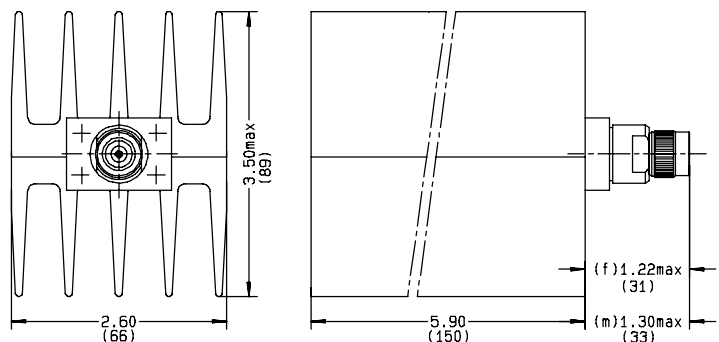

Technical data sheet are available under the www.radiall.com Web site Select "Find a part number", enter the part number then "Search"

120 WATTS HIGH POWER

Part Number	Power peak (W)	Frequency range (GHz)	V.S.W.R. (MAX)			Impedance (Ω)	Type	Weight (g)
			DC-1	1-2	2-4			
R404 882 000	5000	DC-4	1.10	1.20	1.30	50 \pm 5%	M	800
R404 883 000	5000	DC-4	1.10	1.20	1.30	50 \pm 5%	F	800

NOTA : This termination can be used with conduction cooling (120 Watts) or convection cooling (80 Watts).
For conduction cooling a 156 sq. in. plate x 1/8" (1000 cm² x 3 mm) min. is required.

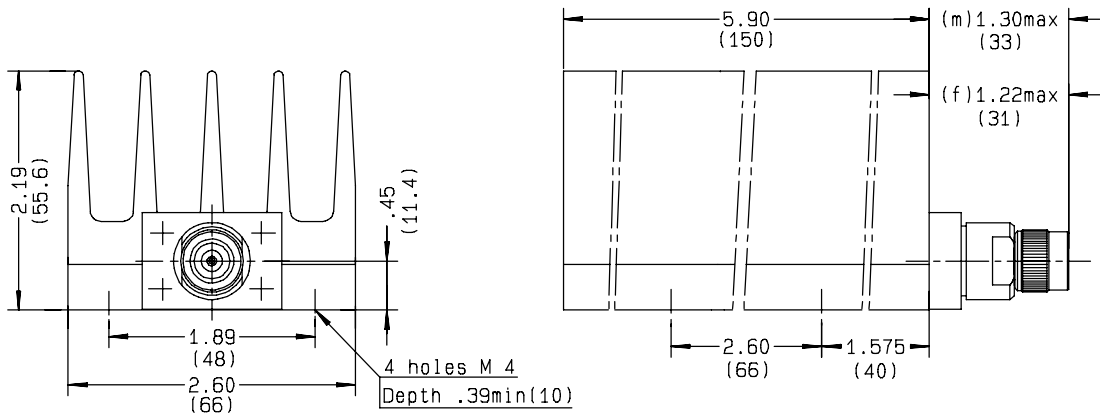
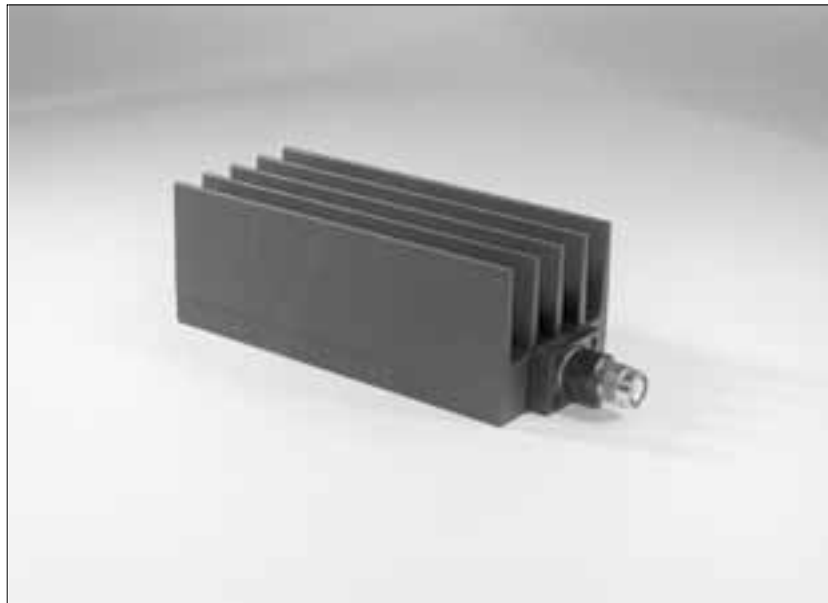

Technical data sheet are available under the www.radiall.com Web site Select "Find a part number", enter the part number then "Search"

1 WATT, QN

Part Number	Power peak (W)	Frequency range (GHz)	V.S.W.R. (MAX)		Impedance (Ω)	Type	Obs.
			DC-1	1-4			
R404 116 000	100	DC-4	≤ 1.08	≤ 1.20	$50 \pm 5\%$	M	
R404 116 120	100	DC-4	≤ 1.08	≤ 1.20	$50 \pm 5\%$	M	2
R404 116 121	100	DC-4	≤ 1.08	≤ 1.20	$50 \pm 5\%$	M	1

OBS :1) With .275" (70mm) cord



OBS :2) With .275" (70mm) bead chain

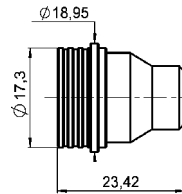

1 - 2 WATTS, N

Part Number	Power		Frequency range (GHz)	V.S.W.R. (MAX)					Impedance (Ω)	Type	Obs.	Fig.
	avg. (W)	peak (W)		DC-1.5	1.5-4	4-8	8-12.4	12.4-18				
R404 055 000	1	500	DC-1.5	1.10					$75 \pm 2\%$	M	2	1
R404 055 120	1	500	DC-1.5	1.10					$75 \pm 2\%$	M	1-2	1
R404 056 000	1	500	DC-1.5	1.10					$75 \pm 2\%$	F	2	1
R404 056 120	1	500	DC-1.5	1.10					$75 \pm 2\%$	F	1-2	1
R404 131 000	1	500	DC-4	1.10	1.20				$50 \pm 2\%$	M		1
R404 131 120	1	500	DC-4	1.10	1.20				$50 \pm 2\%$	M	1	1
R404 132 000	1	500	DC-4	1.10	1.20				$50 \pm 2\%$	F		1
R404 132 120	1	500	DC-4	1.10	1.20				$50 \pm 2\%$	F	1	1
R404 240 000	1	500	DC-12.4	1.05		1.10	1.15		$50 \pm 2\%$	M		2
R404 240 120	1	500	DC-12.4	1.05		1.10	1.15		$50 \pm 2\%$	M	1	2
R404 240 121	1	500	DC-12.4	1.05		1.10	1.15		$50 \pm 2\%$	M	3	2
R404 245 000	1	500	DC-12.4	1.06		1.12	1.15		$50 \pm 2\%$	F		2
R404 340 000	2	100	DC-18	1.08		1.10	1.15	1.20	$50 \pm 2\%$	M		2
R404 340 120	2	100	DC-18	1.08		1.10	1.15	1.20	$50 \pm 2\%$	M	1	2
R404 355 000	2	100	DC-18			1.20			$50 \pm 2\%$	F		2

OBS :1) With 2.75" (70 mm) Bead Chain

2) 75Ohms connector

3) With 2.75" (70 mm) Cord

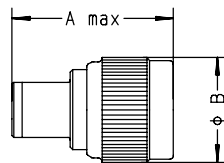

Fig. 1

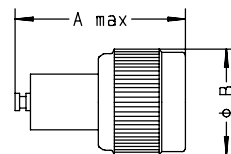

Fig. 2

Part Number	A inch (mm)	B inch (mm)	Weight (g)
R404 055 000	1.34" (34)	.83" (21)	40
R404 055 120	1.49" (38)		
R404 056 000	1.37" (35)	.63" (16)	35
R404 056 120	1.53" (39)		
R404 131 000	1.34" (24)	.83" (21)	40
R404 131 120	1.49" (38)		
R404 132 000	1.37" (35)	.63" (16)	40
R404 132 120	1.53" (39)		

Part Number	A inch (mm)	B inch (mm)	Weight (g)
R404 240 000	1.40" (35.5)	.83" (21)	40
R404 240 120		.63" (16)	
R404 240 121			
R404 245 000	1.45" (37)		35

6 - 12 WATTS MEDIUM POWER

Part Number	Power		Frequency range (GHz)	V.S.W.R. (MAX)					Impedance (Ω)	Type
	avg. (W)	peak (W)		DC-2	2-4	4-8	8-12.4	12.4-18		
R404 507 000	6	4000	DC-2	1.10					50 \pm 5%	M
R404 517 000	6	4000	DC-12.4		1.10	1.20	1.30		50 \pm 5%	M
R404 522 000	6	300	DC-18		1.15	1.20	1.25	1.30	50 \pm 5%	M
R404 522 500	6	300	DC-18		1.15	1.20	1.25	1.30	50 \pm 5%	F
R404 557 000	12	4000	DC-2	1.10					50 \pm 5%	M
R404 567 000	12	4000	DC-12.4		1.10	1.20	1.30		50 \pm 5%	M
R404 572 000	12	300	DC-18		1.15	1.20	1.25	1.30	50 \pm 5%	M
R404 572 500	12	300	DC-18		1.15	1.20	1.25	1.30	50 \pm 5%	F

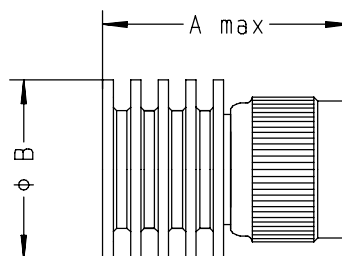

Part Number	A inch (mm)	B inch (mm)	Weight (g)
R404 507 000	1.44" (36.5)	1.02" (26)	44
R404 517 000	1.77" (45.5)		60
R404 522 000	1.77" (45.5)		60
R404 522 500	1.74" (44.5)		50

Part Number	A inch (mm)	B inch (mm)	Weight (g)
R404 557 000	1.95" (49.5)	1.38" (35)	88
R404 567 000	1.99" (50.5)		90
R404 572 000	1.99" (50.5)		90
R404 572 500	1.95" (49.5)		80

Technical data sheet are available under the www.radiall.com Web site Select "Find a part number", enter the part number then "Search"

20 WATTS MEDIUM POWER

Part Number	Power peak (W)	Frequency range (GHz)	V.S.W.R. (MAX)				Impedance (Ω)	Type	Weight (g)
			DC-4	4-8	8-12.4	12.4-18			
R404 587 000	300	DC-12.4	1.15	1.20	1.25		50 \pm 5%	M	100
R404 587 500	300	DC-12.4	1.15	1.20	1.25		50 \pm 5%	F	100
R404 588 000	300	DC-18		1.20	1.25	1.35	50 \pm 5%	M	100
R404 588 500	300	DC-18		1.20	1.25	1.35	50 \pm 5%	F	100

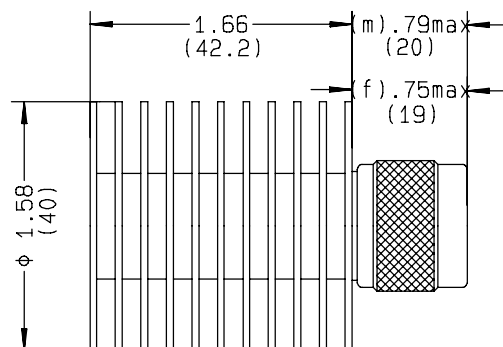

30 WATTS MEDIUM POWER

Part Number	Power peak (W)	Frequency range (GHz)	V.S.W.R. (MAX)		Impedance (Ω)	Type	Weight (g)
			DC-2	2-4			
R404 830 000	5000	DC-4	1.10	1.20	50 \pm 5%	M	140
R404 831 000	5000	DC-4	1.10	1.20	50 \pm 5%	F	140

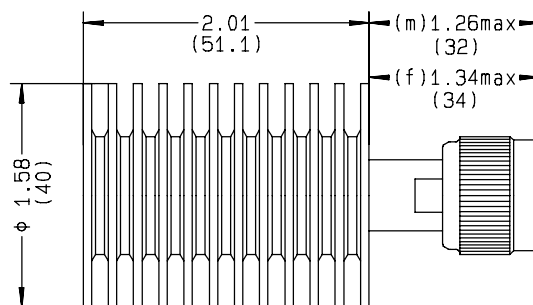

Technical data sheet are available under the www.radiall.com Web site Select "Find a part number", enter the part number then "Search"

Coaxial Terminations

STANDARD COAXIAL TERMINATIONS N

50 WATTS MEDIUM POWER without cooling fins

Part Number	Power peak (W)	Frequency range (GHz)	V.S.W.R. (MAX)		Impedance (Ω)	Type	Weight (g)
			DC-2	2-4			
R404 870 000	5000	DC-4	1.10	1.20	50 \pm 5%	M	140
R404 871 000	5000	DC-4	1.10	1.20	50 \pm 5%	F	140

NOTA : This termination can be used with conduction cooling (50 Watts) or convection cooling (25 Watts).
For conduction cooling a 78 sq. in. plate x 1/8" (500 cm² x 3 mm) min. is required.

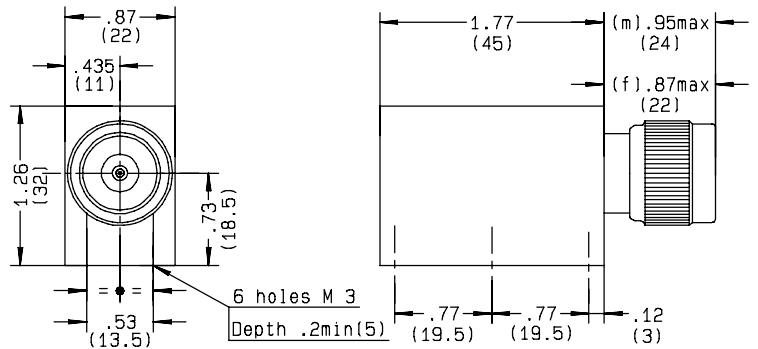

50 WATTS MEDIUM POWER with cooling fins

Part Number	Power peak (W)	Frequency range (GHz)	V.S.W.R. (MAX)		Impedance (Ω)	Type	Weight (g)
			DC-2	2-4			
R404 840 000	5000	DC-4	1.10	1.20	50 \pm 5%	M	320
R404 841 000	5000	DC-4	1.10	1.20	50 \pm 5%	F	320

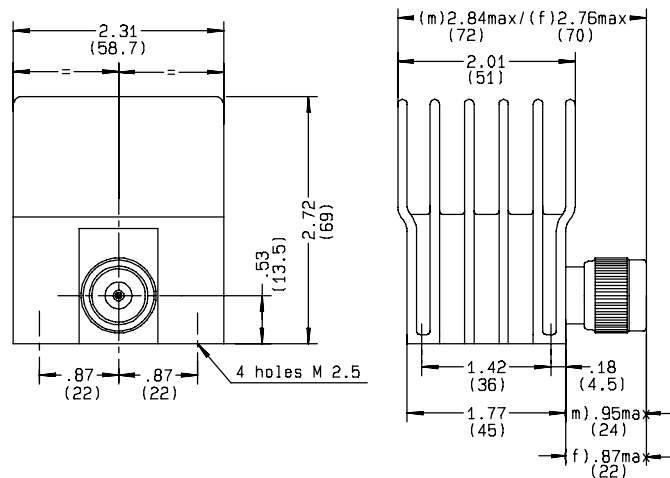
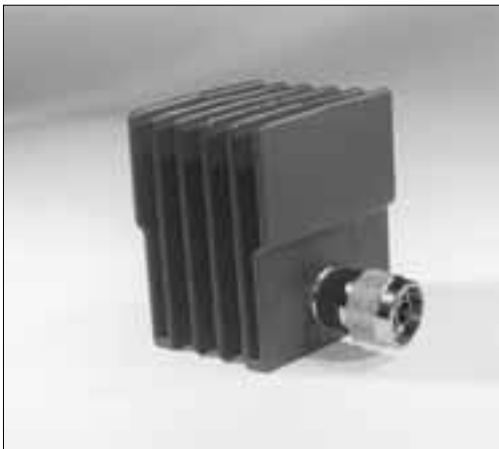

Technical data sheet are available under the www.radiall.com Web site Select "Find a part number", enter the part number then "Search"

100 WATTS HIGH POWER

Part Number	Power peak (W)	Frequency range (GHz)	V.S.W.R. (MAX)			Impedance (Ω)	Type	Weight (g)
			DC-1	1-2	2-4			
R404 850 000	5000	DC-4	1.10	1.20	1.30	50 \pm 5%	M	1000
R404 851 000	5000	DC-4	1.10	1.20	1.30	50 \pm 5%	F	1000

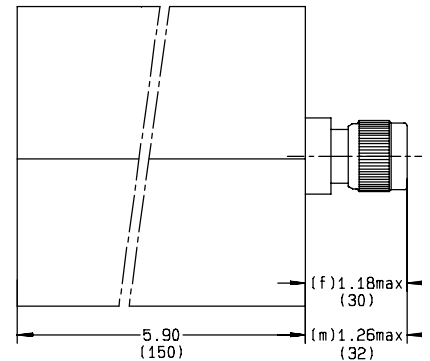
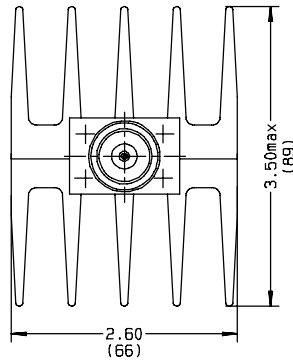
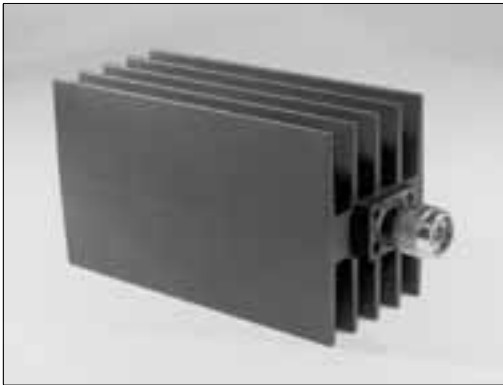

120 WATTS HIGH POWER

Part Number	Power peak (W)	Frequency range (GHz)	V.S.W.R. (MAX)			Impedance (Ω)	Type	Weight (g)
			DC-1	1-2	2-4			
R404 880 000	5000	DC-4	1.10	1.20	1.30	50 \pm 5%	M	800
R404 881 000	5000	DC-4	1.10	1.20	1.30	50 \pm 5%	F	800

NOTA : This termination can be used with conduction cooling (120 Watts) or convection cooling (80 Watts).
For conduction cooling a 156 sq. in. plate x 1/8" (1000 cm² x 3 mm) min. is required.

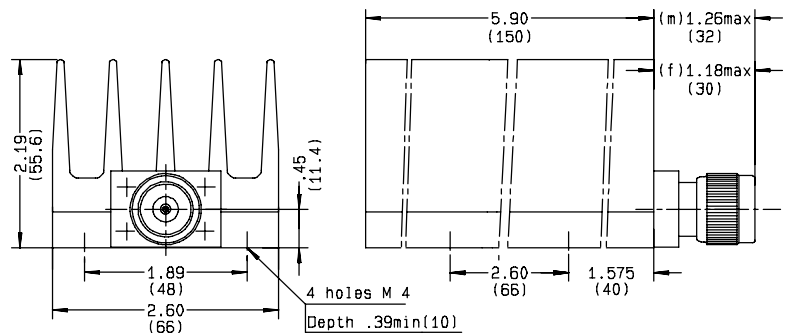
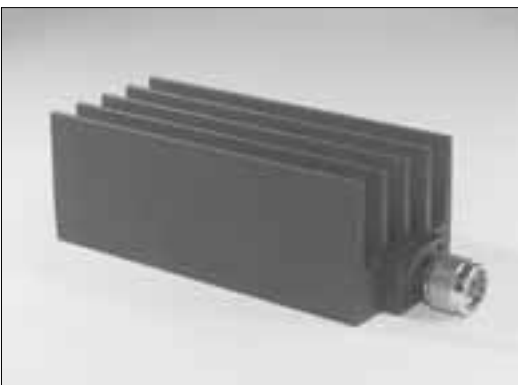

Technical data sheet are available under the www.radiall.com Web site Select "Find a part number", enter the part number then "Search"

1 WATT CALIBRATED TERMINATION SET

Part Number	Power peak (W)	Frequency range (GHz)	V.S.W.R	V.S.W.R ACCURACY		Type
			DC-4	DC-1	1-4	
R404 188 000	500	DC-4	1.00	± 3%	± 5%	M
	500	DC-4	1.20	± 3%	± 5%	M
	500	DC-4	1.50	± 3%	± 5%	M
	500	DC-4	2.00	± 3%	± 5%	M

NOTA : certificate of calibration for each termination is provided within the case.



Technical data sheet are available under the www.radiall.com Web site Select "Find a part number", enter the part number then "Search"

2 WATTS

Part Number	Power		Frequency range (GHz)	V.S.W.R. (MAX)			Impedance (Ω)	Type	Weight (g)	Fig.
	avg. (W)	peak (W)		DC-2	1-2	2-4				
R404 170 111		500	DC-4	1.10		1.30	$50 \pm 5\%$	M	120	1
R404 175 111		500	DC-4	1.10		1.30	$50 \pm 5\%$	F	115	2

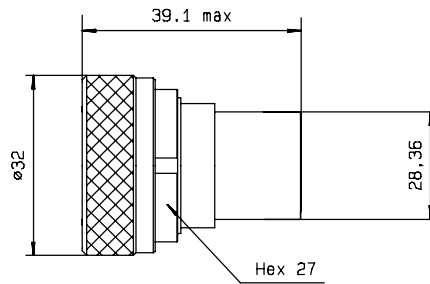

Fig. 1

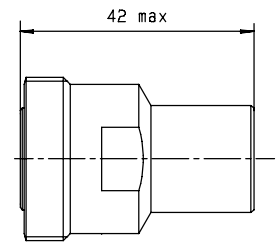

Fig. 2

12 - 25 WATTS MEDIUM POWER

Part Number	Power		Frequency range (GHz)	V.S.W.R. (MAX)			Impedance (Ω)	Type	Weight (g)	Fig.
	avg. (W)	peak (W)		DC-1	1-2	2-4				
R404 564 000	12	4000	DC-4	1.10	1.10	1.20	$50 \pm 5\%$	M	170	1
R404 564 500	12	4000	DC-4	1.10	1.10	1.20	$50 \pm 5\%$	F	165	2
R404 836 118	25	5000	DC-2	1.10	1.20		$50 \pm 5\%$	M	210	3
R404 837 118	25	5000	DC-2	1.10	1.20		$50 \pm 5\%$	F	205	4

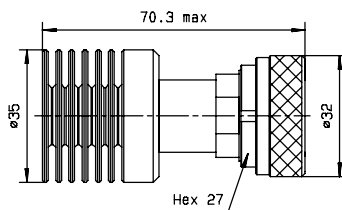

Fig. 1

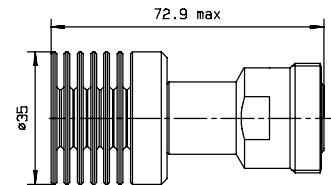

Fig. 2

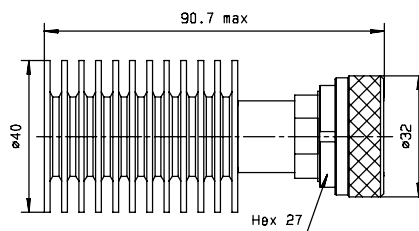

Fig. 3

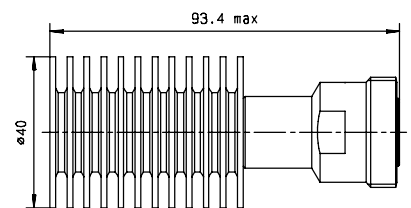
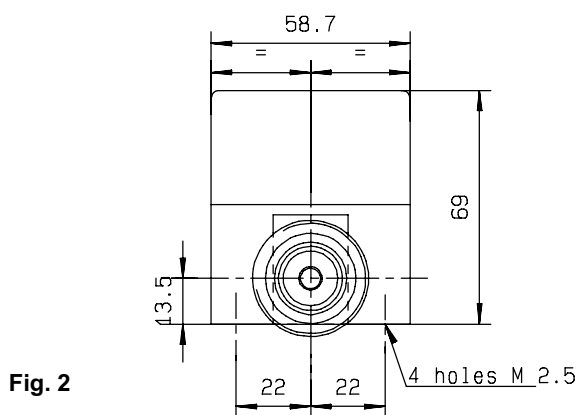
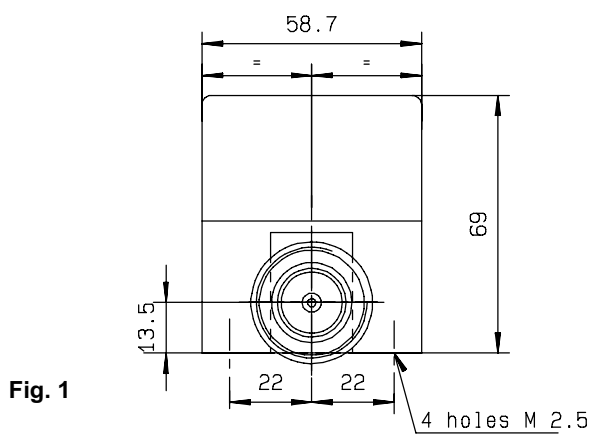

Fig. 4

Technical data sheet are available under the www.radiall.com Web site Select "Find a part number", enter the part number then "Search"

50 WATTS MEDIUM POWER

Part Number	Power peak (W)	Frequency range (GHz)	V.S.W.R. (MAX)		Impedance (Ω)	Type	Weight (g)	Fig.
			DC-1	1-2				
R404 846 118	5000	DC-2	1.10	1.20	50 \pm 5%	M	380	1
R404 847 118	5000	DC-2	1.10	1.20	50 \pm 5%	F	375	2



Technical data sheet are available under the www.radiall.com Web site Select "Find a part number", enter the part number then "Search"

100 WATTS HIGH POWER

Part Number	Power	Frequency range (GHz)	V.S.W.R. (MAX)		Impedance (Ω)	Type	Weight (g)	Fig.
	peak (W)		DC-1	1-2				
R404 856 118	5000	DC-2	1.10	1.20	50 \pm 5%	M	1050	1
R404 857 118	5000	DC-2	1.10	1.20	50 \pm 5%	F	1045	2

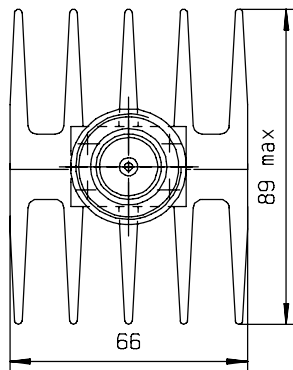

Fig. 1

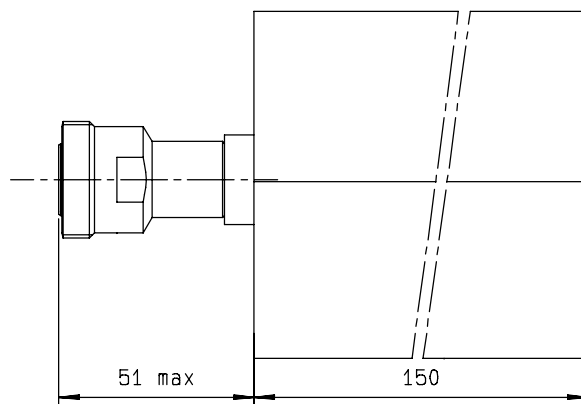
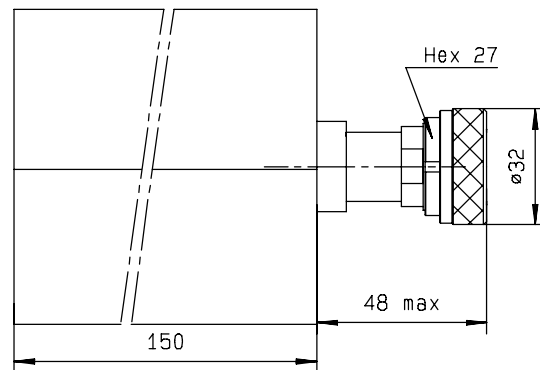
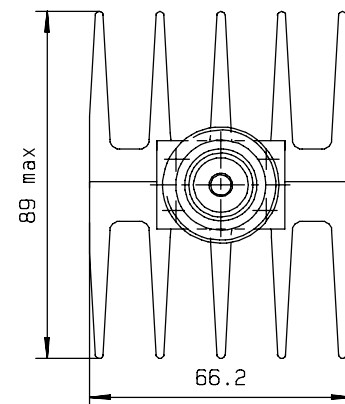

Fig. 2



Technical data sheet are available under the www.radiall.com Web site Select "Find a part number", enter the part number then "Search"

2 WATTS

Part Number	Power	Frequency range (GHz)	V.S.W.R. (MAX)		Impedance (Ω)	Type	Obs	Weight (g)
	peak (W)		DC-0.5	0.5-1				
R405 005 000	1000	DC-1	1.20	1.35	50 \pm 5%	M/F	1	30
R405 006 000	1000	DC-1	1.20	1.35	75 \pm 5%	M/F	1-2	30

OBS :1) VSWR on female input connector, the output connector is in open circuit.
2) 75 Ohms connector

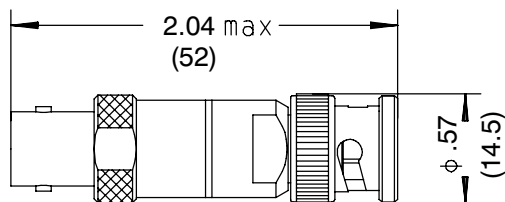

Part Number	Power	Frequency range (GHz)	V.S.W.R. (MAX)		Impedance (Ω)	Type	Obs	Weight (g)
	peak (W)		DC-0.5	0.5-1				
R405 035 000	1000	DC-1	1.35	1.50	50 \pm 5%	M/F	1	21

OBS :1) VSWR on female input connector, the output connector is in open circuit.

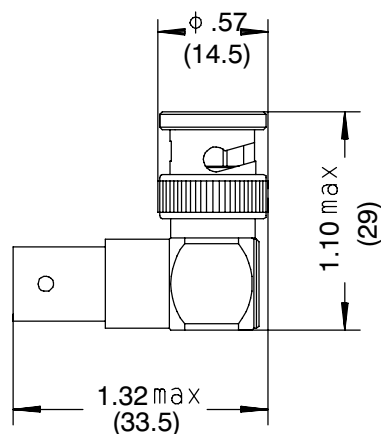

PREFERRED PRODUCTS LIST MICROWAVE COMPONENTS :

Förderverein Für Elektrotechnische Normung e.V.
Cenelec Electronic Components Committee
Military Usage And Harmonisation
Advisory Group

CECC

MUAHAG

LISTE PREFERENTIELLE
DE
COMPOSANTS
ELECTRONIQUES



COMPOSANTS

TOME
VOLUME **12**
BAND

Fixed attenuators (coaxial) - Z=50 Ω

Specification	Identif. General Style	Manufacturer		Cat./ Qual.	Characteristics			Att. (dB)	Connector	E.I. Initial Category	Observations		
		Country/Code	Part No.		F100a)	PDM)							
						C.W.	Peak						
MFC9315		FR/RAY	84144XX	8/WG	0-8	2-3		3-6-10-20-30-40	SWC w/f	55/125/21			
			84145XX	8/WG	0-12,4	1,3		3-6-10-20	TWC w/f	55/125/21			
			84147XX	8/WG	0-12,4	2-3		3-6-10-20-30-40	W w/f	55/125/21			
			84148XX	8/WG	0-2	2-3		3-6-10-20-30-40	SWC w/f	55/125/21			
			84127XX	8/WG	0-2	2-3		3-6-10-20-30	W w/f	55/125/21			
			84118XX119	8/WG	0-8	2-3,5		3-6-10-20	SWA w/f	55/125/21			
			84118X	8/WG	0-15	2-3,5		3-6-10-20	SWA w/f	55/125/21			
			84118XX121	8/WG	0-18	2-3,5		3-6-10-20	SWA w/f	55/125/21			
			84138XX	8/WG	0-18	2		0...20	SWC w/f	55/125/21			
			84138XX121	8/WG	0-26,3	2		3-6-10-20	W w/f	55/125/21			
			84147XX161	8/WG	0-18	2		3-6-10-20	TWC w/f	55/125/21			
			84145XX161	8/WG	0-18	2		3-6-10-20	SWA w/f	55/125/21			
			8415XXX	8/WG	0-8	10-15		3-6-10-20	TWC w/f	55/125/21			
			84160XX	8/WG	0-18	10-15		3-6-10-20	W w/f	55/125/21			
			FR/RAY	8418035	8/WG	0-4		0-5		0-5	W w/f	55/125	10dB steps
			8418040	8/WG	0-4			0-25		0-25	W w/f	55/125	50dB steps
		8418045	8/WG	0-4			0-50		0-50	W w/f	55/125	10dB steps	
		8418050	8/WG	0-12,4			0-5		0-5	W w/f	55/125	10dB steps	
		8418055	8/WG	0-12,4			0-25		0-25	W w/f	55/125	50dB steps	
		8418050	8/WG	0-12,4			0-50		0-50	W w/f	55/125	10dB steps	
		8419133	8/WG	2-12,4			0-20		0-20	SWA f	55/125	const induct	
		8419157	8/WG	2-12,4			0-40		0-40	W f	55/125	const induct	
		8419233	8/WG	7-18			0-20		0-20	SWA f	55/125	const induct	

MANUFACTURERS CODE NUMBERS

RADIALL, manufacturer code **F0503** and **F6507**, is a military qualified supplier of terminations, as well as other microwave components, to various governmental agencies. RADIALL Quality Assurance is fully approved by NATO (AQAP4)

The following is a partial listing of national stock numbers which RADIALL has provided to the French Ministry of Defence.

PART NUMBERS	NATO CODE	PART NUMBERS	NATO CODE	PART NUMBERS	NATO CODE
R404 005 000	6625 14 355 5453	R404 130 000	5985 14 277 1118	R404 240 120	6625 14 372 3759
R404 010 000	5985 14 310 8255	R404 130 120	5985 14 376 1063	R404 240 121	5985 14 397 2304
R404 010 120	5985 14 384 0240	R404 150 000	5985 14 288 0737	R404 245 000	5985 14 340 1728
R404 011 000	5985 14 291 5327	R404 155 000	5985 14 291 5333	R404 340 000	5985 14 340 1729
R404 011 120	5985 14 361 9005	R404 160 000	5985 14 386 6923	R404 507 000	5985 14 406 8776
R404 012 000	5985 14 279 7545	R404 165 000	5985 14 377 8787	R404 517 000	5985 14 288 0736
R404 012 120	5985 14 358 4865	R404 210 000	5985 14 287 4618	R404 555 000	5985 14 424 4698
R404 021 120	5985 14 404 9842	R404 210 120	5985 14 399 4588	R404 567 000	5985 14 419 4304
R404 050 000	5985 14 285 9043	R404 212 000	5985 14 353 7813	R404 600 000	5985 14 412 0431
R404 051 000	5985 14 279 7538	R404 212 120	5985 14 373 0231	R404 605 000	5985 14 347 3889
R404 051 120	5985 14 383 9220	R404 215 000	5985 14 340 1730	R404 692 000	5985 14 400 0144
R404 053 000	5985 14 285 9042	R404 220 000	5985 14 257 9817	R405 005 000	5985 14 288 0770
R404 110 000	5985 14 291 5176	R404 225 000	5985 14 041 1592	R405 006 000	5985 14 291 5193
R404 110 120	5985 14 387 9871	R404 240 000	5985 14 257 9818	R405 035 000	6625 14 357 3167



RADIALL high Reliability SPACE QUALIFIED attenuators have been designed and are built to satisfy the stringent demands of space environment via intensive manufacturing and quality procedures, such as European Space Agency ESA / SCC.



1 - 2 watts DC - 18 - 22 & 40 GHz range :

- 1) This range of terminations can be delivered :
 ESA qualified products (ESA certificate N° 185). They can be supplied to different levels of tracability (B or C) and Lot Acceptance Tests (LAT 1,2 or 3.) according to ESA generic specification ESCC3403 and detail specification ESCC3403004 & 006.

Cross references RADIALL / ESA :

RADIALL P/N	ESA SPECIFICATION P/N	Tracability level
R404 210 600	340300402B	FM / B
R404 210 650	340300402C	FM / C
R404 210 602	340300401B	FM / B
R404 210 652	340300401C	FM / C
R404 213 600	340300601B	FM / B
R404 213 650	340300601C	FM / C
R404 219 600	340300602B	FM / B

RADIALL P/N	ESA SPECIFICATION P/N	Tracability level
R404 219 650	340300602C	FM / C
R404 370 600	340300603B	FM / B
R404 370 650	340300603C	FM / C
R404 213 655	340300601	EM
R404 219 655	340300602	EM
R404 370 655	340300603	EM

- 2) RADIALL qualified products as High Reliability products according to RADIALL specification RAD-GEN-ATCH-001 up to 40 GHz

RADIALL P/N	RADIALL SPECIFICATION
R404 213 651	RAD-GEN-ATCH-001
R404 280 651	RAD-GEN-ATCH-001
R404 285 651	RAD-GEN-ATCH-001



Microwave performances :

RADIALL P/N	CONNECTORS	FREQUENCY RANGE (GHz)	VSWR Max				
			DC - 4	4 - 8	8 - 12.4	12.4 - 18	18 - 22
R404 210 6XX	SMA M	DC - 18 GHz	1.05+0.0125*F(GHz)			1.30	
R404 213 600	SMA M	DC - 22 GHz	1.05	1.15		1.20	1.30
R404 213 650	SMA M	DC - 22 GHz	1.05	1.15		1.20	1.30
R404 213 651	SMA M	DC - 22 GHz	1.05	1.15		1.20	1.30
R404 213 655	SMA M	DC - 22 GHz	1.05	1.15		1.20	1.30
R404 219 600	SMA F	DC - 22 GHz	1.05	1.15		1.25	1.30
R404 219 650	SMA F	DC - 22 GHz	1.05	1.15		1.25	1.30
R404 219 655	SMA F	DC - 22 GHz	1.05	1.15		1.25	1.30
R404 370 6XX	TNC M	DC - 18 GHz	1.08	1.10	1.15	1.20	
R404 280 651	SMA 2.9 M	DC - 40 GHz	1.30				
R404 285 651	SMA 2.9 F	DC - 40 GHz	1.30				

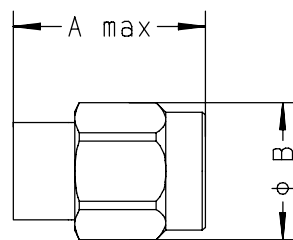

Part Number	A inch (mm)	B inch (mm)	Weight (g)
R404 210 600	.47" (12)	.25" (6.4)	3.5
R404 210 650			
R404 210 602			
R404 210 652			
R404 213 600	.65" (16.5)	.30 (7.7)	5
R404 213 650			
R404 213 651			
R404 213 655			
R404 219 600			
R404 219 650	.56" (14.3)		
R404 219 655			
R404 370 6xx	.99" (25)	.51 (13)	2.3
R404 280 651	.72" (18.4)	.30 (7.7)	5.5
R404 285 651	.76" (19.3)		



12 W medium power termination panel model designed for use in classified military airborne ECM system.

CUSTOM TERMINATIONS :

Contact RADIALl for your specific requirements.

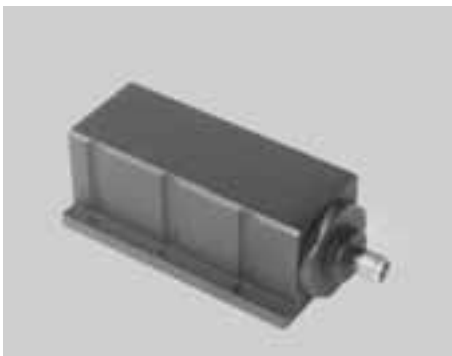

80 W panel mounting termination designed for use in a very rugged military environment.



12 W panel mounting termination developed for space application (TELECOM II) freq. range 3.7–4.2GHz.



50 W panel mounting termination designed for use in broadcasting station.



50 W High Power coaxial termination with coupled output.



Low level termination with earthing connection designed for use on ETHERNET systems.

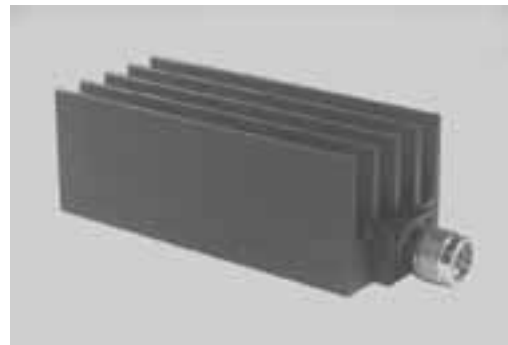

120 W mounting panel termination Issued from standard product with special frequency range.

Coaxial Terminations

PART NUMBER INDEX

Part Numbers	Avg. Power(W)	Connect.	Page	Part Numbers	Avg. Power(W)	Connect.	Page	Part Numbers	Avg. Power(W)	Connect.	Page
R404 005 000	1	BNC	38	R404 160 000	0.5	SMC	19-38	R404 521 500	6	TNC	24
R404 010 000	1	BNC	21-38	R404 165 000	0.5	SMB	18-38	R404 522 000	6	N	29
R404 010 120	1	BNC	21-38	R404 170 111	2	7/16	34	R404 522 500	6	N	29
R404 011 000	1	BNC	38	R404 175 111	2	7/16	34	R404 523 000	6	SMA	14
R404 011 120	1	BNC	38	R404 188 000	1	N	33	R404 523 500	6	SMA	14
R404 012 000	1	BNC	21-38	R404 210 000	2	SMA	13-38	R404 555 000	12	BNC	22-38
R404 012 120	1	BNC	21-38	R404 210 120	2	SMA	13-38	R404 556 000	12	TNC	24
R404 014 000	1	BNC	21	R404 210 161	2	SMA	13	R404 557 000	12	N	29
R404 014 120	1	BNC	21	R404 212 000	1	SMA	13-38	R404 560 000	12	BNC	22
R404 021 120	1	BNC	38	R404 212 120	1	SMA	13-38	R404 564 000	12	7/16	34
R404 050 000	1	BNC	38	R404 212 122	1	SMA	13	R404 564 500	12	7/16	34
R404 051 000	1	BNC	38	R404 213 000	2	SMA	13	R404 566 000	12	7/16	34
R404 050 120	1	BNC	38	R404 215 000	2	SMA	13-38	R404 567 000	12	N	29-38
R404 053 000	1	BNC	38	R404 219 000	2	SMA	13	R404 568 000	12	SMA	14
R404 055 000	1	N	28	R404 220 000	1	BNC	21-38	R404 568 500	12	SMA	14
R404 055 120	1	N	28	R404 220 120	1	BNC	21	R404 571 000	12	TNC	24
R404 056 000	1	N	28	R404 225 000	1	TNC	23-38	R404 571 500	12	TNC	24
R404 056 120	1	N	28	R404 225 120	1	TNC	23	R404 572 000	12	N	29
R404 101 000	1	SMA	13	R404 225 121	1	TNC	23	R404 572 500	12	N	29
R404 101 120	1	SMA	13	R404 240 000	1	N	28-38	R404 573 000	12	SMA	14
R404 102 000	1	SMA	13	R404 240 120	1	N	28-38	R404 573 500	12	SMA	14
R404 102 120	1	SMA	13	R404 240 121	1	N	28-38	R404 584 000	20	SMA	15
R404 104 000	1	SMB	18	R404 245 000	1	N	28-38	R404 584 500	20	SMA	15
R404 104 120	1	SMB	18	R404 270 000	1	BMA	20	R404 585 000	20	TNC	24
R404 105 000	1	SMB	18	R404 260 000	0.5	SMP	12	R404 585 500	20	TNC	24
R404 105 120	1	SMB	18	R404 262 000	0.5	SMP	12	R404 586 000	20	TNC	24
R404 110 000	1	BNC	21-38	R404 275 000	1	BMA	20	R404 586 500	20	TNC	24
R404 110 120	1	BNC	21-38	R404 280 000	0.5	SMA 2.9	13	R404 587 000	20	N	30
R404 111 000	1	BNC	21	R404 285 000	0.5	SMA 2.9	13	R404 587 500	20	N	30
R404 111 120	1	BNC	21	R404 340 000	2	N	28-38	R404 588 000	20	N	30
R404 111 121	1	BNC	21	R404 340 120	2	N	28	R404 588 500	20	N	30
R404 112 000	1	BNC	21	R404 355 000	2	N	28	R404 589 000	20	SMA	15
R404 112 120	1	BNC	21	R404 370 000	2	TNC	23	R404 589 500	20	SMA	15
R404 114 000	1	QMA	12	R404 370 120	2	TNC	23	R404 600 000	1	BNC	38
R404 114 120	1	QMA	12	R404 375 000	2	TNC	23	R404 605 000	1	BNC	38
R404 114 121	1	QMA	12	R404 380 000	0.5	SSMA	20	R404 692 000	1	BNC	38
R404 114 250	3	QMA	12	R404 412 000	1	BNC	22	R404 830 000	30	N	30
R404 116 000	1	QN	28	R404 441 000	1	BNC	22	R404 831 000	30	N	30
R404 116 120	1	QN	28	R404 441 120	1	BNC	22	R404 832 000	30	TNC	25
R404 116 121	1	QN	28	R404 441 121	1	BNC	22	R404 833 000	30	TNC	25
R404 121 000	1	TNC	23	R404 442 000	1	BNC	22	R404 834 000	30	SMA	15
R404 121 120	1	TNC	23	R404 442 120	1	BNC	22	R404 835 000	30	SMA	15
R404 122 000	1	TNC	23	R404 443 000	1	BNC	22	R404 836 118	25	7/16	34
R404 122 120	1	TNC	23	R404 443 120	1	BNC	22	R404 837 118	25	7/16	34
R404 130 000	1	BNC	38	R404 505 000	6	BNC	22	R404 840 000	50	N	31
R404 130 120	1	BNC	38	R404 506 000	6	TNC	24	R404 841 000	50	N	31
R404 131 000	1	N	28	R404 507 000	6	N	29-38	R404 842 000	50	TNC	26
R404 131 120	1	N	28	R404 510 000	6	BNC	22	R404 843 000	50	TNC	26
R404 132 000	1	N	28	R404 516 000	6	TNC	24	R404 844 000	50	SMA	16
R404 132 120	1	N	28	R404 517 000	6	N	29-38	R404 845 000	50	SMA	16
R404 144 000		1DIN 1.0/2.3	12	R404 518 000	6	SMA	14	R404 846 118	50	7/16	35
R404 150 000	0.5	SMC	19-38	R404 518 500	6	SMA	14	R404 847 118	50	7/16	35
R404 155 000	0.5	SMB	18-38	R404 521 000	6	TNC	24				

Part Numbers	Avg. Power(W)	Connect.	Page	Part Numbers	Avg. Power(W)	Connect.	Page	Part Numbers	Avg. Power(W)	Connect.	Page
R404 850 000	100	N	32	R404 870 000	50	N	31	R404 882 000	120	TNC	27
R404 851 000	100	N	32	R404 871 000	50	N	31	R404 883 000	120	TNC	27
R404 852 000	100	TNC	26	R404 872 000	50	TNC	25	R404 884 000	120	SMA	17
R404 853 000	100	TNC	26	R404 873 000	50	TNC	25	R404 885 000	120	SMA	17
R404 854 000	100	SMA	17	R404 874 000	50	SMA	16				
R404 855 000	100	SMA	17	R404 875 000	50	SMA	16	R405 005 000	2	BNC	37-38
R404 856 118	100	7/16	36	R404 880 000	120	N	32	R405 006 000	2	BNC	37-38
R404 857 118	100	7/16	36	R404 881 000	120	N	32	R405 035 000	2	BNC	37-38

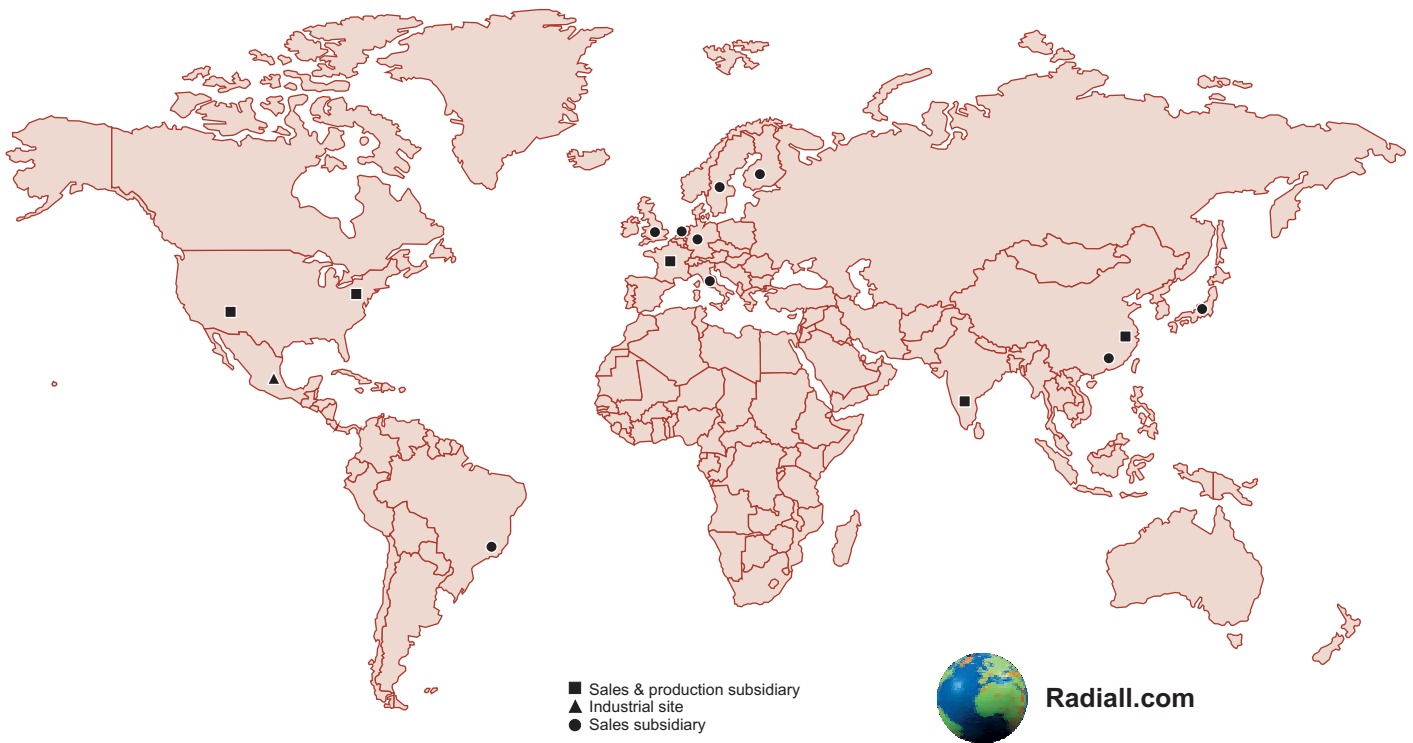

RADIALL WORLDWIDE LOCATIONS

EUROPE

France - RADIALL HEADQUARTERS
 101, Rue Ph. Hoffmann - 93116 ROSNY sous BOIS (Paris)
 Tel. : +33 1 49 35 35 35 Fax : +33 1 48 54 63 63
 E-Mail : info@radiall.com

Finland - RADIALL SF
 Pilot Business Park - Lentokatu 2 - FIN-90460 OULUNSALO
 Tel. : +358 852 70 130 Fax : +358 852 70 105
 E-Mail : info@radiall.fi

Germany - RADIALL GmbH
 Carl-Zeiss Str. 10 Postfach 200143 - D63307 RÖDERMARK (Frankfurt)
 Tel. : +49 60 74 91 07 0 Fax : +49 60 74 91 07 70
 E-Mail : infode@radiall.com
 Regional office : Munich

Italy - RADIALL Elettronica SRL
 Via Concordia, 5 - 20090 ASSAGO MILANO
 Tel. : +39 02 48 85 121 Fax : +39 02 48 84 30 18
 E-Mail : radiall@tin.it
 Regional office : Roma

Netherlands - RADIALL BV
 Hogebrinkerweg 15b - 3871 KM HOEVELAKEN
 Tel. : +31 33 253 40 09 Fax : +31 33 253 45 12
 E-Mail : info@radiall.com

Sweden - RADIALL AB
 Sjöängsvägen 2 - SE-192 72 SOLLENTUNA (Stockholm)
 Tel. : +46 844 434 10 Fax : +46 875 449 16
 E-Mail : info@radiall.com

U.K. - RADIALL Ltd
 Ground Floor, 6 The Grand Union Office Park, Packet Boat Lane
 UXBRIDGE Middlesex UB8 2GH (London)
 Tel. : +44 1895 425 000 Fax : +44 1895 425 010
 E-Mail : info@radiall.com



This information is intended as a guide only. To ensure a continuing policy of product improvement, Radiall reserves the right to modify its specifications without prior notification.

AMERICA

North America
RADIALL
 6825 West Galveston Street Suite 11
 CHANDLER, Arizona 85226, USA
 Tel. : +1 480 682 9400 Fax : +1 480 682 9403
 E-Mail : infousa@radiall.com

RADIALL-AEP
 104 John W. Murphy Drive
 NEW HAVEN, Connecticut 06513
 Tel. : +1 203 776 2813 Fax : +1 203 776 8294
 E-Mail : aepsales@aep.us

Brazil
RADIALL do Brasil
 Largo do Machado, 54 sala 706 - Catete
 22221-020 RIO DE JANEIRO
 Tel. : +55 21 2558 05 76 Fax : +55 21 2245 97 63
 E-Mail : hubertm@radiall.com.br

ASIA

China - SHANGHAI RADIALL Electronic Co., Ltd
 N° 390 Yong He Road 200072 - SHANGHAI
 Tel. : +86 21 66 52 37 88 Fax : +86 21 66 52 11 77
 E-Mail : sales.rsh@radiall.com

Japan - NIHON RADIALL
 Shibuya-ku Ebisu 1-5-2, Kougetsu Bldg 405-TOKYO 150-0013
 Tel. : +81 3 3440 6241 Fax : +81 3 3440 6242
 E-Mail : kunii@radiall.co.jp

HongKong - RADIALL Electronics Ltd
 Elite Industrial Centre, Room 212, 2/F
 N° 883 Cheung Sha Wan Road - KOWLOON HONG KONG
 Tel. : +852 29 59 38 33 Fax : +852 29 59 26 36
 E-Mail : contact@radiall.com.hk

India - RADIALL PROTECTRON pvt Ltd
 25 D, II Phase, Peenya Industrial Area - BANGALORE 560058
 Tel. : +91 80 23 72 09 89 Fax : +91 80 28 39 72 28
 E-Mail : radiall@vsnl.com

REPRESENTED IN

- | | | | |
|-----------|-------------|--------------|----------|
| Africa | Greece | Russia | Thailand |
| Australia | Israël | Singapore | Taiwan |
| Belgium | Malaysia | Spain | Turkey |
| China | Philippines | South Africa | USA |
| Denmark | Poland | South Korea | |
| France | Portugal | Switzerland | |

For the above countries, please contact the local agent or RADIALL at info@radiall.com

D1M404CE - 2007 March Edition



Printed in France